



**WATER ENGINEERING
STANDARDS AND SPECIFICATIONS**

M *Castle Pines North*
METROPOLITAN DISTRICT



**WATER ENGINEERING
STANDARDS AND SPECIFICATIONS**



7404 Yorkshire Drive
Castle Pines, CO 80108
Phone: 303-688-8550

Prepared By:
Kennedy/Jenks Consultants, Inc.
143 Union Boulevard, Suite 600
Lakewood, CO 80228
Phone: 303-985-3636

Adopted July 21, 2014
Revised April 19, 2016
Job Number: 1346068*00

TABLE OF CONTENTS

WATER SYSTEM STANDARDS AND SPECIFICATIONS

<u>Section</u>	<u>Title</u>	<u>Page</u>
1	Purpose and General Requirements	1
2	Location of Lines and Appurtenances	3
3	Hydraulic Design, Fire Flow, and Meter Sizing	5
4	Pipe Specifications	12
5	Water Main Equipment (Valves, fire hydrants, etc.)	16
6	Mechanical Water Piping	33
7	Concrete Encasement and Steel Casings	40
8	Trenching, Bedding, and Backfill	44
9	Installation of Water Mains	50
10	Protection of Water Lines Near Sanitary Sewer Facilities	56
11	Disinfection and Testing	57

PROCEDURES

<u>Section</u>	<u>Title</u>	<u>Page</u>
12	Construction Plan Review and Approval	64
13	Conveyance and Acceptance Procedure	66
14	Water Easements	67
15	Pre-Construction and Construction Procedures	73
16	Acceptance and Release for Taps	76
17	Water Line Tapping Procedures	77

NOTES AND DETAILS

<u>Section</u>	<u>Title</u>	<u>Page</u>
18	General Water Notes	84
19	Detail Drawings	87

1. PURPOSE AND GENERAL REQUIREMENTS

1.1 Purpose

These Standards provide information to Engineers, Contractors, Builders, Developers and other interested parties, on the District requirements with respect to the design and construction of water systems within the District. These Standards present technical specifications for the design and installation of the water mains and should be used in conjunction with the District Rules and Regulations by any firm or individual planning to design or construct water systems within the District. In all cases in these specifications where reference is made to "District Engineer", the "District Engineer" shall mean any representative of the Consulting Engineering firm or other individual designated by the District.

1.2 General Requirements

- 1.2.1 All plans for water main extensions, improvements, and changes shall be submitted to the District Manager. All plans must be reviewed and approved by the District Manager and the District Engineer.
- (a) All plans to be reviewed must be accompanied by four (4) sets of the standard District "Application for Main Line Extension". These shall be processed by the Owner/Developer and presented to the District Manager prior to plan approval. When construction has been completed and accepted by the District, the applications shall be dated and signed by the District Manager and approved by the District Engineer. The probationary acceptance period shall begin at that time.
- No taps will be allowed, nor "Connection Permits" issued, until water main construction has been accepted by the District and all applicable fees have been paid.
- (b) Plans to be reviewed must be accompanied by two (2) copies of the AutoCAD files, version 2007 to 2011.
- (c) Prior to approval, plans to be reviewed must be accompanied by three (3) sets of the recorded plat(s). One copy shall be retained by the District Manager, one copy delivered to the District Engineer, and one copy delivered to the District Attorney.
- (d) If any water main is to be constructed outside of a public right-of-way, the construction plans must be accompanied by request for acceptance of water easement in accordance with Section 14 of these specifications.
- 1.2.2 A preconstruction meeting must be arranged by the Contractor and held prior to the start of any work. The District Engineer, District Manager, Contractor, the Owner or Owner's Engineer, Owner's Surveyor, and Owner's Soils Consultant shall be represented at this meeting. The meeting shall be held at the District office at 7404 Yorkshire Drive, Castle Pines, CO 80108, or at such place as the District Manager shall direct.
- 1.2.3 All Contractors must notify the District Engineer and District Manager at least 48 hours prior to the start of construction.

- 1.2.4 Approved plans and a copy of these specifications must be kept on the job site by the Contractor at all times.
- 1.2.5 No work shall be backfilled (including bedding material above the spring-line of the pipe) until construction has been reviewed by the District Engineer.

1.3 **Special Requirements**

The requirements listed below are unique to CPNMD and must be strictly followed. No exceptions will be allowed.

- 1.3.1 Tracer Wire – Tracer wire is required on all new water lines, regardless of pipe type. Refer to Section 5.11.
- 1.3.2 Easements – Water lines located in easements must strictly follow District Standards and requirements. Refer to Section 14.
- 1.3.3 Tap and Meter Sizing – The District will determine tap and meter size for new construction in strict conformance with Section 3.2.
- 1.3.4 All valves and fire hydrants are **open-left**. Fire hydrants are to be factory-painted RED in color.
- 1.3.5 Swimming Pools – The District will review swimming pool designs on a case-by-case basis, specifically how each pool is connected to the District's water and sanitary sewer system. In general, the engineer is to provide a plan for how the pool will be filled and how make-up water will be provided. Include the anticipated demands (in gpm) for when these activities take place.

2. LOCATION OF WATER LINES AND APPURTENANCES

2.1 Water Mains in Streets

2.1.1 When the water mains are placed in streets, they shall generally be placed as follows:

- On streets running north and south, the water main shall be placed 10' (ten feet) east of the centerline of the street.
- On streets running east and west, the water main shall be placed 10' (ten feet) north of the centerline of the street.
- On streets shaped as a "U" or on streets having unusually sharp turns, the water main will conform to the above specifications as near as practical.
- No water main shall be located closer than 3' (three feet) from the lip of a pan or gutter.
- A minimum horizontal distance of 10-feet shall be maintained between potable water mains and sanitary sewer mains.
- A minimum vertical distance of 18-inches, pipe wall to wall, shall be maintained at utility crossings between water mains and other utilities.

2.2 Water Mains in Easements

2.2.1 When water mains are placed in easements, they shall be placed per the standards in Section 14.

2.3 Valves

2.3.1 Valves shall be located, where possible, at a point on the main which will be intersected by the extension of a property line, a right-of-way line or an easement line. When it is necessary to deviate from this standard, the District Engineer shall review and approve the proposed location of the valve.

2.3.2 Valves located outside of pavement shall be marked using a steel marker post per District detail. The top-of-valve box shall be set at an elevation 4" to 6" above final grade. A concrete collar shall be installed around the valve box top section.

2.3.3 Valves shall be located to allow for isolation of each fire hydrant and to minimize the number of service connections out of service in the event of a main failure.

2.4 Water Services

2.4.1 Services shall be located a minimum of 5-feet from property lines.

- 2.4.2 Water services shall be located on the up-hill side from sanitary sewer services or underdrain.
- 2.4.3 Water services shall be located a minimum of 10-feet horizontally from sanitary sewer and underdrain services.
- 2.4.4 Variations from these standards must be approved by the District Engineer prior to plan approval.

2.5 Fire Hydrants

- 2.5.1 Fire hydrants shall be located, where directed by the responsible Fire Protection District, a minimum of 18" (eighteen inches) behind the curb or sidewalk and on property lines whenever possible. All fire hydrant street valves shall be 6" (six inches) and shall be located at the tee from the main line.
- 2.5.2 All fire hydrant locations must be approved by the Fire Protection District in which the main is located. The standard acceptance block for the Fire Protection District shall be placed on the cover sheet. The required fire flow must be listed and the acceptance block must be signed prior to the District's review. See the example acceptance block below:

FIRE DEPARTMENT APPROVAL

ALL FIRE HYDRANTS SHALL BE INSTALLED ACCORDING TO CASTLE PINES NORTH METROPOLITAN DISTRICT STANDARDS. THE NUMBER OF FIRE HYDRANT LOCATIONS AS SHOWN ON THESE PLANS ARE CORRECT AND ADEQUATE TO SATISFY THE FIRE PREVENTION REQUIREMENTS AS SPECIFIED BY THE SOUTH METRO FIRE PROTECTION DISTRICT.

SIGNATURE OF FIRE CHIEF OR REPRESENTATIVE

ESTIMATED FIRE FLOW: _____ GPM

DATE

3. HYDRAULIC DESIGN, FIRE FLOW, AND METER SIZING

3.1 Hydraulic Design and Fire Flow

3.1.1 Water Demand

- (a) Water lines shall be designed to transport 1) peak hour demands or 2) peak day demands plus fire flow, whichever is greater, in accordance with these Specifications. The water demand criteria presented in Tables 3.1 and 3.2 are minimum criteria, and the District reserves the right to modify the criteria, at any time, for the design of specific projects. The criteria presented in Table 3.1 shall be used for hydraulic design and planning. Where the water demand criteria for the proposed use are not listed in Table 3.1, the criteria presented in Table 3.2 shall be used.
- (b) An allowance for irrigation is included in the demand criteria presented in Table 3.1, with the exception of car washes and schools. Irrigation demands for schools and parks shall be added based on the irrigation demand criteria in Table 3.1, the approved irrigation plan, and/or the proposed size of the irrigation tap for the project (Table 3.2). Irrigation should be designed to take place during off-peak demand hours. Peaking factors should not be applied to irrigation demands.
- (c) The Castle Pines North Metropolitan District is within the jurisdiction of South Metro Fire Protection District. It is the Developer/Engineer's responsibility to contact the Fire Protection Agency and establish the required fire flow and hydrant locations for each specific project.
- (d) Definitions: SFE is a "Single Family Equivalent"; ADD is "Average Day Demand"; PDD is "Peak Day Demand"; PHD is "Peak Hour Demand".

**Table 3.1
WATER DEMAND CRITERIA BASED ON LAND USE**

LAND USE	Typical ADD/Unit	Typical SFEs/Unit
Single Family Residential and Duplexes	400 gpd/dwelling unit	1.00/dwelling unit
Multi-Family Residential (Townhomes and Condos)	300 gpd/dwelling unit	0.75/dwelling unit
Retail/Offices	0.2 gpd/SF	0.0005/SF
Hotels/Motels	75 gpd/room	0.19/room
Restaurants	3.0 gpd/SF	0.0075/SF
Car Washes	5,000 gpd/facility	12.5/facility
Industrial/Other Commercial	1,200 gpd/acre	3.0/acre
Institutional	800 gpd/acre	2.0/acre
Elementary School (10 ac, 675 students)	3,375 gpd/school (5 gpd/student)	8.44/school
Middle School (25 ac, 850 students)	8,500 gpd/school (10 gpd/student)	21.25/school
High School (50 ac, 1,700 students)	17,000 gpd/school (10 gpd/student)	42.50/school
Churches	600 gpd/church	1.5/church
Irrigated Land	2,000 gpd/acre	5.0/acre

**Table 3.2
WATER DEMAND CRITERIA BASED ON TAP SIZE**

TAP SIZE (PER SECTION 3.2)	Single Family Equivalents (SFEs)
¾"	1
1"	2
1.5"	4
2"	8
3"	18
4"	36

(e) Demand and Peaking Criteria:

Average Day Demand (ADD) = 400 gpd/SFE
 Peak Day Demand (PDD) = 2.5 x ADD
 Peak Hour Demand (PHD) = 5.5 x ADD

3.1.2 Design Criteria

- (a) All water mains will be a minimum of six (6) inches in diameter. Where a fire hydrant is to be installed, the water main serving the fire hydrant will be a minimum of 8" (eight inches) in diameter.
- (b) Water mains shall be "looped" with at least two (2) feeds, unless otherwise approved by the District, or per Item (c) below.
- (c) Dead-end water mains located in cul-de-sacs: Water mains with only one feed located in cul-de-sacs will be a minimum of 6" (six inches) in diameter. Based on flow projections from the District, the length of the dead-end water main, the number of water services on the main, and input from the Fire Protection District, these water mains may need to be larger than the minimum requirements listed above. A maximum of 15 lots are allowed on dead-end water mains in cul-de-sacs.

3.1.3 Storage Requirements

- (a) The minimum required storage volume associated with a particular development shall be computed as follows:

$$\text{Storage Volume (MG)} = [(\text{PHD} - \text{PDD}) \times 8 \text{ hours}] + \text{Fire Flow Volume}$$

Fire flow volume shall be based on the required fire flow rate and duration as determined by South Metro Fire Protection District.

- (b) Based on the computed storage volume, the District will evaluate whether the development is compatible with the location and magnitude of the existing storage volume within the pressure zone, or if additional storage must be considered to provide the appropriate level of service to the development.

3.1.4 Water Supply Requirements

- (a) The required water supply associated with a particular development shall be equal to the Peak Day Demand (PDD) calculated using the criteria listed above.
- (b) Based on the required water supply, the District will evaluate whether the development is compatible with the District's existing water supply, or if additional supply must be considered to provide the appropriate level of service to the development.

3.1.5 Treatment Requirements

- (a) The required treatment capacity associated with a particular development shall be equal to the Peak Day Demand (PDD) calculated using the criteria listed above.
- (b) Based on the computed treatment capacity, the District will evaluate whether the development is compatible with the capacity of the existing treatment facility, or if additional treatment capacity must be considered to provide the appropriate level of service to the development.

3.1.6 Minimum Hydraulic Performance Criteria

**Table 3.3
MAXIMUM VELOCITY AND ALLOWABLE HEADLOSS (C=130)**

PIPE SIZE	MAXIMUM VELOCITY (fps)	MAXIMUM ALLOWABLE HEADLOSS PER 1000 FT. OF PIPE
6"	10	
8"	10	
12"	10	
16"		1.5
20"		1.5
24" and larger		1.0

For Hazen-Williams "C" factor = 130

(a) **Peak Demand Conditions:**

A variety of peak demand, or critical demand conditions, exist for different types of developments. Peak conditions shall be reviewed by the designing Engineer with the highest demand condition being used to size water lines. Some typical peak demand conditions include: peak hour demand; peak day demand plus fire flow. Maximum velocity during peak day + fire flow demands is 10 ft/sec.

(b) **System Pressure Requirements:**

Static pressures within the water system shall be a **minimum of 50 psi** and a **maximum of 125 psi**.

During peak day plus fire flow demand conditions, the residual pressure at any fire hydrant shall be 20 psi, minimum. The maximum allowable pressure fluctuation between average demand conditions and peak hour demand conditions shall be 30 psi.

Where static water pressures exceed 80 psi, individual pressure reducing valves shall be installed on water services, as required by the Uniform Plumbing Code.

(c) The pressure criteria listed above for the peak day plus fire flow conditions and for the peak hour conditions shall be satisfied with one critical loop out of service.

(d) **Submittals:** The design Engineer shall prepare a hydraulic analysis model and submit system hydraulic sizing calculations upon request.

3.1.7 Operating Pressures and Pressure Zone Characteristics

(a) The required operating pressures listed above apply to pressures within the water mains and shall be satisfied in accordance with the general pressure zone elevation data tabulated in Table 3.4 below.

**Table 3.4
PRESSURE ZONE CHARACTERISTICS**

PRESSURE ZONE	STATIC HGL	MINIMUM ELEVATION SERVED	MAXIMUM ELEVATION SERVED
1A	6550	6261	6357
1B	6494	6205	6357
2	6669	6380	6554
4	6700	6411	6554

Notes:

1. Zone 2 is served by the District's storage tanks.
 2. Zone 4 is served by a booster pump station
 3. Zones 1A and 1B are reduced from Zone 2.
 4. Minimum elevations listed are based on a maximum pressure of 125 psi.
 5. Maximum elevations listed for Zones 1A, 1B, and 4 are based on the actual maximum elevations currently served.
 6. The maximum elevation listed for Zone 2 is based on a minimum pressure of 50 psi.
- (b) Elevations shown above are general guidelines. The design Engineer shall contact the District to confirm the appropriate numbers for a specific site.

3.2 Tap, Meter, and Service Line Sizing

3.2.1 General

- (a) The minimum size of service and meter will be three-quarter inch (3/4").
- (b) All single-family detached residences will be served with a minimum diameter 3/4-inch service line and meter.
- (c) Each multi-family residential building will be served by an individual service line and meter for each living unit or, if an HOA is established, by a single service line and meter for the building.
- (d) The most current AWWA M22 manual shall be used to size multi-family and commercial water services and meters in strict accordance with Section 3.2.2 of these Standards. No other method or manual for sizing service lines will be permitted, used, or considered for determining the size of the tap, meter, and service line.
- (e) A set of mechanical plumbing plans showing plumbing fixtures must be submitted to the District Engineer for the purpose of sizing the tap, meter, and service line from the main to the meter. The District Engineer will determine the size of the tap, meter, and service line.

- (f) The tap, corporation stop, meter, and that portion of the service line between the corporation stop and 5 feet past the meter shall be the same size. The service line may be increased in size to the next approved larger diameter beginning 5 feet downstream of the meter. This is permitted to satisfy maximum pressure loss criteria – it is not for achieving greater flow using a smaller tap.

3.2.2 Meter Sizing Method for Multi-Family and Non-Residential Buildings

The procedure for sizing the tap and meter for multi-family residential units and non-residential buildings shall be exclusively guided by the procedure outlined in the American Water Works Association (AWWA) Manual M22, latest edition and as outlined below.

- (a) The estimated peak demand for sizing meter and service lines shall be calculated per AWWA Manual M22, Chapter 4 (Manual). Fixture values shall be as indicated in Figure 4-5 of the Manual. Irrigation demand shall not be included provided that irrigation is performed during off-peak hours. Hose bibs shall not be included in the fixture count provided they are used for irrigation during off-peak hours or for emergencies. Hose bibs shall be included in the fixture count if they will be used for cleaning or wash-down purposes. All multi-family and non-residential (commercial) uses shall use the higher of the two curves to calculate peak demand on Figures 4-2 and 4-3 of the Manual.
- (b) The estimated peak demand shall be multiplied by the corresponding pressure factor from Table 4-1 of the Manual. The pressure used to determine the pressure factor shall be the actual static pressure at the main as provided by Lakehurst Water and Sanitation District. For main pressures over 80 psi, the maximum pressure factor shall be 1.17, indicated as the pressure factor for 80 psi. All locations where static pressure at the main is greater than 80 psi will require a pressure reducing valve on the downstream side of the meter.
- (c) The estimated peak demand multiplied by the pressure factor shall be used, and strictly followed, to determine the meter size as follows:
 - i. Table 6-1 of the Manual, using 80% of the “maximum Flow Rate”, OR
 - ii. 80% of manufacturer’s maximum continuous operating range for approved meters. Approved manufacturer is Badger Meter, Inc.
- (d) The maximum allowable fixtures for ¾” and 1” meters as determined by the AWWA M22 Manual are:

<u>Meter Size</u>	<u>Max. Fixture units</u>
¾”	16 fixture units
1”	27 fixture units

- (e) The maximum number of multi-family units on a single meter, regardless of fixture count or anticipated peak demand, shall be as follows:

¾” Meter	1 Dwelling Unit
1” Meter	2 Dwelling Units
1 ½” Meter	20 Dwelling Units

- (f) The total pressure drop in the service line from the main to the building shall not exceed 25 psi without backflow prevention or 35 psi and a minimum residual pressure of 20 psi at the building beyond any backflow prevention device under peak domestic demand flow.
- (g) Fire sprinkler requirements and demand shall be served by a separate fire service line. Service sizing shall be the responsibility of the applicant's Professional Engineer.

The District will determine the proposed tap, meter, and service line size that insures adequate pressure and flow and meter accuracy for the customer. The District has final approval authority as to the required size of the tap, meter, and service line.

4. PIPE SPECIFICATIONS

4.1 General

All water pipe shall be polyethylene wrapped ductile iron pipe, unless otherwise approved by the District.

Tracer wire is required on all new water lines, regardless of pipe type. Refer to Section 5.11.

Minimum design working pressure shall be 150 psi. Minimum design transient or water hammer pressure shall be: 135 psi for 6" and 8" diameter lines; 125 psi for twelve-inch (12") diameter lines; and 85 psi for sixteen-inch (16") and larger diameter lines. Pipe design calculations shall be submitted to the District, upon request.

4.2 Ductile Iron Pipe

- 4.2.1 Size of Pipe – This specification shall cover all sizes of ductile iron pipe 24" (twenty four inches) in diameter and smaller.
- 4.2.2 Pipe furnished shall be manufactured in accordance with AWWA C151 under method of design outlined in AWWA C150.
- 4.2.3 Unless otherwise specifically required by CPNMD or the Fire Protection District, the wall thickness shall be Pressure Class 350 or Special Class 50.
- 4.2.4 Pipe furnished shall have normal laying length of 18' (eighteen feet) or 20' (twenty feet).
- 4.2.5 Iron used in the manufacture of pipe shall have 60/42/10 iron strength.
- 4.2.6 External Pipe Coating: Shall be an asphaltic coating approximately 1-mil thick.
- 4.2.7 Internal Lining: Pipe furnished shall have standard thickness cement-mortar lining in accordance with AWWA C104. Minimum standard thickness per AWWA C104 is as follows:

<u>Pipe & Fitting Size</u>	<u>Minimum Thickness of Lining</u>
4" – 12"	1/16"
14" – 24"	3/32"

4.2.8 **Acceptable Pipe Manufacturers**

American Cast Iron Pipe
Griffin Pipe Products
Pacific States Cast Iron Pipe
United States Pipe and Foundry

4.2.9 **Mechanical Joint Restraint**

- (a) Mechanical joint restraints shall be incorporated in the design of a follower gland. The gland shall be manufactured in accordance with ASTM A 536.

- (b) Dimensions of gland shall be used with standard mechanical joint bell and tee-head bolts conforming to AWWA C111 and C153.
- (c) Minimum working pressure of 350 psi for pipe sizes 3" – 16" and 250 for pipe sizes 18" – 42" with a minimum safety factor of 2:1.
- (d) Acceptable Restraints:
 - EBA Iron, Megalug 1100 Series (4"-36") or equal with prior approval by District

4.2.10 Push-On Joint Pipe Restraint

- (a) Standard spigot end bell, and pipe socket shall conform to AWWA C151.
- (b) Push-on joints shall conform to AWWA C111.
- (c) Pressure Ratings shall be 350 psi for 4" – 24", 250 psi for 30" – 64".
- (d) Gasket type restraining devices are not acceptable.
- (e) Acceptable Restraints applied to Standard Push-on Bell per AWWA C111:
 - EBA Iron, Megalug 1700 Series (4"-36") or equal with prior approval by District

4.2.11 Restrained Joint DIP (to be used only with District approval)

- (a) Acceptable Restained Joint Pipe:
 - American Flex-Ring (4"-36") or Lok-Ring (42"-64")
 - US Pipe TR-Flex (4"-64")
 - Griffin Snap-Lok (4"-48")
 - Pacific States Perma-Lok (4"-24")

4.2.12 Polyethylene Encasement

Pipe furnished shall have polyethylene encasement, minimum thickness 8 mils, installed per District detail 5W. Refer to Section 5.7.

4.3 Polyvinyl Chloride (PVC) Pipe

- 4.3.1** Applicable for PVC pressure pipe 4-inches to 12-inches in diameter (AWWA C900). The use of PVC pressure pipe for water lines greater than 12-inches in diameter (AWWA C905) requires prior approval by the District Engineer.
- 4.3.2** AWWA C900 DR18, Poly (Vinyl Chloride) (PVC) material; inside nominal diameters 4-inches through 12-inches, bell and spigot style rubber rings sealed gasket joint. AWWA C909 PVC may be substituted with prior approval by the District Engineer.

4.3.3 Acceptable Manufacturers:

Certain-Teed Corporation
JM Eagle
Extrusion Technologies, Inc.
Ipex, Inc.
Diamond Plastic Corporation
For AWWA C909: JM Eagle Ultra Blue

4.3.4 Joints: Pipe joints shall be made using an integral bell with an elastomeric-gasket push-on type joint. Elastomeric-gaskets shall meet the requirements of ASTM F477 for high head applications.

4.3.5 Mechanical Joint Restraint

- (a) Mechanical joint restraints shall be incorporated in the design of a follower gland. The gland shall be manufactured of ductile iron in accordance with ASTM A536.
- (b) Dimensions of gland shall be used with standard mechanical joint bell and tee-head bolts conforming to ASTM C111 or C153.
- (c) Working pressure of the restraint device shall be equivalent to the full rated pressure of the PVC pipe, with a minimum safety factor of 2:1.
- (d) Acceptable Restraint:

EBA Iron, Megalug 2000 PV Series (4"-12") or equal with prior approval by District

4.3.6 Push-on Joint Pipe Restraint

- (a) Standard spigot end bell, and pipe socket shall conform to AWWA C900.
- (b) Gasket type restraining devices are not acceptable.
- (c) Acceptable Restraint:

EBA Iron, Megalug 1500 PV Series (4"-12") or equal with prior approval by District

4.3.7 Restrained Joint PVC Pipe (to be used only with District approval)

- (a) Acceptable Restrained Joint Pipe: Certa-Lok by Certain-Teed

4.4 Steel Pipe (to be used only with District approval)

Steel pipe shall only be installed with prior approval by the District Engineer. Specifications for steel pipe must be submitted for review by the District, with means for anode placement, exterior coating, and/or cathodic protection.

4.5 Tracer Wire

Tracer wire is required on all new water lines, regardless of pipe type. Refer to Section 5.11.

5. WATER MAIN EQUIPMENT

5.1 Fittings (Bends, Tees, etc.)

All fittings shall be cast iron or ductile iron cement mortar lined, and shall conform to AWWA C110 latest revision for mechanical joints.

- 5.1.1 All cast iron and ductile iron fittings shall be manufactured in accordance with AWWA C104, C110, C111 and C153.
- 5.1.2 Provide Fitting with mechanical (MJ) joints or Push-on (Fastite or Tyton). Refer to Sections 4.2.10 and 4.3.6 "Mechanical Joint Restraint" for restraint for fittings joints.
- 5.1.3 Fittings shall be wrapped in polyethylene, minimum thickness 8 mils, installed per District detail 5W. Refer to Section 5.7.
- 5.1.4 Acceptable Manufacturers:
 - Tyler Pipe Industries
 - Griffin Pipe Products
 - United States Pipe and Foundry
 - Union Foundry Company

5.2 Valves

5.2.1 **General**

- (a) Prepare valves for shipment according to AWWA Standards and seal valve ends to prevent entry of foreign matter into product body.
- (b) Store products in areas protected from weather, moisture, or possible damage; do not store products directly on ground; handle products to prevent damage to interior or exterior surfaces.
- (c) All valves shall have polyethylene encasement. Refer to Section 5.7.
- (d) All valves shall be **open-left (counter-clockwise)**.

5.2.2 **Resilient Wedge Gate Valves**

- (a) AWWA C509; iron body, bronze or ductile iron.
 - i. Resilient seats.
 - ii. Stem: Non-rising bronze stem.
 - iii. Operator Nut: 2-inch square.
 - iv. Open Left (counter-clockwise)
 - v. Coating: AWWA C550; interior/exterior.
 - vi. Sizes 3-inch through 12-inch diameter.
 - vii. 200 psi working pressure.
 - viii. Rubber encapsulated gate and corrosion protected.
 - ix. Markings meeting AWWA C509 that include manufacturer, year of manufacture, maximum working pressure, and size of valve.

(b) End Connections

- i. Furnish valves with end connections as shown on Drawings.
- ii. Mechanical Joint:
 1. For buried installations.
 2. Manufactured in accordance with AWWA C111.
 3. Bolts and hexagon nuts shall be fabricated from high-strength, low alloy steel conforming to ASTM A242. Cor-ten, USAlloy, Ductile Iron Durabolt or equal.
 4. Accessories for the mechanical joint consisting of the gasket, gland and fasteners shall be furnished and packaged separately from the valve. Each package shall be labeled in such a manner as to provide for proper identification and number of units per package or bundle.
- iii. Flanged:
 1. For above ground installations, including vaults.
 2. Sized and drilled in accordance with ANSI-B16.1, Class 125, or to suit adjacent piping.
 3. Flanges shall be machined to a flat surface with a serrated finish in accordance with AWWA C207.
 4. Flange gaskets shall be one-eighth (1/8) inch ring type "Garlock".
 5. All thread studs shall be used on valve flange connections and shall be in accordance with ASTM A307, Grade B, with heavy hex nuts.

(c) Acceptable Manufacturers:

American Flow Control
Mueller
Clow
Kennedy
U.S. Pipe Valve

5.2.3 Butterfly Valves

(a) General

- i. Designed and manufactured per AWWA C504, Class 150B.
- ii. Direct bury or housed in a manhole as indicated on the Construction Drawings.
- iii. Suitable for throttling service or frequent and infrequent operation.
- iv. Capable of operating satisfactorily with flows in either direction, and shall be suitable for use in potable water systems.
- v. Open Left (Counter-clockwise)

(b) Valve Body

- i. Ductile iron, ASTM A536; or
- ii. Cast iron, ASTM A126 or ASTM A48, Class 40
- iii. Short body pattern.

- (c) Pressure Rating: 150 psi working pressure
- (d) Valve Disc
 - i. Cast iron, ASTM A126, Class B
 - ii. Ductile iron, ASTM A536, Grade 65-45-12
 - iii. Type 316 stainless steel edge
 - iv. Valve discs shall seat at 90-degrees to the pipe axis.
- (e) Valve Seat
 - i. Resilient seat per AWWA C504.
 - ii. Cast Iron, ASTM A48, Class 40
 - iii. Ni-resist, ASTM A 436, Type 1
 - iv. Ductile Iron, ASTM A536, Grade 65-45-12
 - v. Fully adjustable and replaceable
 - vi. Buna-N rubber
- (f) Valve Shaft
 - i. Stainless steel.
 - ii. Through or stub type.
 - iii. Horizontal service orientation.
- (g) Shaft Seal
 - i. Self-compensating V-type packing or an O-ring type contained in a corrosion resistant cartridge.
 - ii. 30-inch or larger: Split V-type packing (i.e. Chevron) or pull down type packing of flax.
 - iii. Packing shall be accessible for adjustment or replacement without removing valve shaft.
- (h) Valve Bearings: Valves with externally adjustable thrust bearing shall have the adjusting mechanism enclosed in water-tight housing.
- (i) Interior Lining: Epoxy in accordance with AWWA C550.
- (j) Exterior Coating
 - i. Exterior surfaces, except seating of flanged faces, shall be in accordance with Federal Specifications TT-C-494, two coats.
 - ii. Flange faces shall be coated with Dearborn Chemical "No-Ox-Id", Houghton "Rust-Veto 334" or "Rust-Oleum R-9".
 - iii. After painting, a lubricant compatible rubber seal shall be applied to prevent bonding of two surfaces.
- (k) Hardware: All hardware shall be Type 316 stainless steel.

(l) End Connections

- i. Direct Bury: Mechanical joint manufactured in accordance with AWWA C111.
- ii. Valve and Vault Assemblies:
 - 1. Flanged, sized and drilled in accordance with AWWA C504 and ANSI-B16.1 and compatible with piping; or
 - 2. Mechanical joint manufactured in accordance with AWWA C111.

(m) Actuators

- i. Manual operation
 - ii. Valve shall open with counter-clockwise rotation of nut (left-hand opening).
 - iii. For valve and vault assemblies, install with 21-inch horizontal operator extension required to accommodate vault installation, as shown on the Drawings.
 - iv. Gearing:
 - a. Total enclosed
 - b. Lubricant temperature range: -10° to $+150^{\circ}$ Fahrenheit
 - c. Manufacturer filled lubricant, 80% full
 - d. Self-locking work gear of high tensile bronze and worm or hardened alloy steel with ground and polished threads.
 - e. Supplemented by spur gear attachment to comply with the following conditions of operation for all sizes:
 - i. Minimum turns to fully open or close disc shall be not less than 40.
 - ii. Maximum torque to fully open or close shall not exceed 150-foot pounds when applied to operating nut.
 - v. Link-lever type with high strength steel screw rod. Acceptable Manufacturers:
 - Mueller
 - MDT
 - Limitorque worm gear operator
 - Or approved equivalent
 - vi. Wrench Nuts: Refer to Section 5.5.2.
- (n) Air & Vacuum Valve Assembly: For valve and vault assemblies: Install one (1) 1¼-inch air & vacuum valve assembly on each side of the valve.
- (o) Markings: Body cast in raised letters the name of manufacturer, nominal size, flow direction, working pressure, standard reference, and model number.

(p) Acceptable Manufacturers:

American Flow Control
Clow
Keystone
M&H
Mueller
Pratt

5.2.4 Check Valves

(a) Cushioned Swing Check Valves

- i. Designed and manufactured per AWWA C508
- ii. Body: Globe Style with 125 lb. Class Flanges
- iii. Body, cover, disc, levers: Cast Iron or cast steel
- iv. Seat: Bronze or stainless steel
- v. Seat Ring: Bronze or Rubber (Buna-N)
- vi. Hinge: Stainless steel
- vii. Cushion Cylinder: Metallic corrosion resistant material
- viii. Acceptable Manufacturers: APCO, Series 6000

(b) Rubber Flapper Check Valves

- i. Flanged, flexible disc, full body check valve type with no internal moving parts except the closure disc.
- ii. Minimum Pressure Rating: 250 psi
- iii. Flanges: Conform to ANSI B16.1 Class 125 drilling.
- iv. Body and Bonnet: Ductile Iron, ASTM A-536 Grade 65-45-12
- v. Gasket: Rubber
- vi. Disc: Steel-reinforced Buna-N, ASTM D-2000
- vii. Bonnet Bolts: Steel, SAE Grade 5
- viii. Interior Lining: Epoxy
- ix. Acceptable Manufacturers:

Milliken Series 850
Crispin RF Series
APCO Series 100

5.2.5 Combination Air Relief – Vacuum Breaker Valves:

- (a) These shall be installed at high points on water mains and at all other locations as directed by the District Engineer. Air Relief and Vacuum Breaker Valves shall be located in pre-cast concrete manholes in accordance with the District detail and shall automatically release air from the lines when the lines are being filled with water and shall admit air into the lines when water is being withdrawn in excess of the inflow.
- (b) Designed and manufactured per AWWA C512
- (c) Body and Cover: Cast Iron ASTM A 126, Class B
- (d) Float and Trim: Stainless Steel
- (e) Seat: Buna-N Rubber
- (f) Internal linkage: Stainless Steel
- (g) Maximum working pressure: 150 psi

- (h) Coating: Rust inhibiting primer or black asphalt varnish
- (i) Acceptable Manufacturers:
 - APCO, Series 140 or 150
 - Val-Matic, Series 100
 - Cla-Val, Model 36
- (j) Installation: Per the Manufacturer's recommendations.
- (k) For pipe 12-inches diameter and smaller: one (1) 2" (two-inch) valve shall be installed on the stem between the pipe and relief valve or as shown in the details.

Pipe and fittings used in the relief valve system shall be ductile iron, standard weight, and connections shall be threaded. Gate valves shall be bronze, threaded and shall have handwheels.

5.2.6 Pressure Reducing and Regulating Valves

- (a) Pressure reducing and regulating valves shall be in accordance with District standards and specifications and in accordance with Uniform Plumbing Code.
- (b) Pressure reducing and regulating valves shall be of a type capable of maintaining pre-adjusted downstream pressures varying rates of flow and upstream pressure without causing water hammer.
- (c) Valves shall be hydraulically operated full-port globe valve with flanged end connections, and shall be installed in concrete valve vaults of sufficient size to provide adequate maintenance and operation. Refer to District detail 41W.
- (d) Valves shall have gate valves and pressure gauges on both upstream and downstream sides and shall have bypasses with smaller pressure reducing and regulating valves to handle minimum flows as determined by the District Engineer. All gate valves in vaults shall be capable of being operated from above ground by use of 2" (two inch) square valve keys.
- (e) Remote pressure monitoring (SCADA) may be required.
- (f) Acceptable Manufacturers:
 - Singer, Model 106-PR

5.3 Fire Hydrants

5.3.1 Dry-barrel Break-away Type: AWWA C502; cast-iron body, compression type valve

- (a) Bury Depth: As indicated on the Drawings.
- (b) Hydrant Type: Three-way type with one (1) pumper nozzle and two (2) hose nozzles all located on the same horizontal plane.
- (c) Working pressure: 150 psi maximum.

- (d) Material stress limits: Shop tests for the body and main valve shall be conducted at a pressure of 300 psi.
- (e) Coating: AWWA C550; interior.

5.3.2 Inlet Connection

- (a) Base shall be provided with a mechanical joint inlet to accommodate 6-inch diameter ductile iron pipe complete with plain rubber gasket, gland, bolts and nuts in accordance with AWWA C111.
- (b) The bolts and nuts shall be a high strength low alloy corrosion resistant steel Cor-Ten or equal with a minimum yield of 50,000 pounds per square inch conforming to ASTM A242.
- (c) All mechanical joint accessories shall be attached to hydrant for shipment.

5.3.3 Main Valve Assembly

- (a) Compression type. Seat ring shall be bronze with a machined face and external threads for threading into a bronze drain ring to provide bronze-to-bronze seating for the main valve. The assembly shall be sealed with C-rings.
- (b) Main valve shall be replaceable type fabricated of a resilient material with a threaded bottom plate or nut with a seal to prevent leakage of the hydrant shaft. The upper valve plate material shall be either bronze or epoxy coated ductile iron.
- (c) The valve assembly shall include one or more drain valves that will work automatically with the main valve and drain the barrel when the main valve is in the closed position. All drain tubes shall be bronze lined and sized large enough for the barrel to drain within 12 minutes when the barrel is sized for a 5-foot trench depth.

5.3.4 Operating Shaft and Nut

- (a) The bronze operating nut shall be pentagon shaped with a finished height of 1-1/8 inch. The dimensions from point-to-flat are 1-3/8 inch at the top and at the bottom.
- (b) All hydrants shall be of the dry-top design where an oil reservoir provides permanent lubrication of the operating nut threads.
- (c) A stop nut located in the hydrant bonnet on the operating shaft shall prevent over travel of the main valve when being opened.
- (d) The hydrant shall open by turning the operating nut to the **left in a counter-clockwise direction** and shall have an arrow on top of the bonnet to designate the direction of opening.

5.3.5 Pumper Connection and Cap

- (a) Pumper Connection: 4-½-inches. Thread size: National Standard.
- (b) Nozzle cap shall be furnished with a synthetic rubber gasket installed in a retaining groove and the dimensions and shape of the nozzle cap nut shall be the same as the operating shaft nut as described above.
- (c) Nozzle caps shall be furnished with security chains with one end of each securely attached to the upper barrel section of the hydrant.

5.3.6 Hose Connections and Caps

- (a) Hose Connections: 2-½-inches. Thread size: National Standard.
- (b) Nozzle caps shall be as specified above.

5.3.7 Finish: Factory-painted, primer and two coats of **RED** alkyd enamel color in accordance with fire department requirements.

5.3.8 Acceptable Manufacturers

Mueller Modern Centurion
Mueller Centurion Model 423
Waterous Pacer WB-67-250

5.4 Blow-Off Assemblies

5.4.1 6-inch Blow-Off Assemblies

- (a) 6-inch blow-off assemblies shall be installed at each low point or dead-end point on all water mains larger than 12" (twelve inches). Such blow-off assemblies shall be fire hydrants or blow-off assemblies per District detail 14W. Fire hydrants may be installed as blow-offs only where approved by the District.

5.4.2 2-inch Blow-Off Assemblies

- (a) 2-inch blow-off assemblies shall be installed at each dead-end point on all water mains 12" (twelve inches) and smaller per District detail 13W. This criteria shall apply to both temporary and permanent dead ends.
- (b) Pipe: 2-inch Diameter Copper Tubing: ASTM B88, Type K, annealed. Brass pipe may be used with prior approval by the District.
- (c) Valves: 2-inch ball valves with stop-and-waste and 2-inch operating nut.
- (d) Valve Boxes: Refer to Section 5.5.
- (e) Valve Operating Nut Extension Shaft: Refer to Section 5.5.
- (f) Bedding and Backfill Materials: Refer to Section 8.
- (g) Installation: Refer to Section 9.

5.5 Accessories

5.5.1 Valve Boxes

- (a) For buried installations.
- (b) Valve box parts shall be made of gray cast iron, ASTM A48, Class 20A. Use of an aluminum alloy as a material for valve boxes is not acceptable.
- (c) Valve boxes shall be three-piece adjustable screw type, 6-inch diameter.
- (d) Covers shall be marked with the word "WATER" and shall have a lip or flange extending into the valve box shaft. No slip-type boxes will be permitted.

- (e) Acceptable Manufacturers: Tyler Pipe Company – Type “C” cast iron valve box assembly Series No. 6860 with No. 160 oval base; Clay & Bailey Screw-Type 6-inch cast iron valve box assembly No. P-108 with No. 160 large oval base.

5.5.2 Operators

(a) General:

- i. Manufactured in accordance with AWWA C509.
- ii. Direction of rotation to open each valve shall be left (counter-clockwise).
- iii. Operators shall be wrench nuts for buried applications and handwheels for above ground applications, including vaults.

(b) Wrench Nuts:

- i. For buried installations.
- ii. Dimensions: 1-15/16 in. square at top, 2 in. square at base, 1-3/4 in. high.
- iii. Nuts shall have flanged base on which shall be cast an arrow at least 2 in. long showing the direction of opening. The word ‘OPEN’ in 1/2 in. letters shall be cast on the nut to indicate the direction to turn when opening the valve.
- iv. The maximum torque required to fully open or close the valve shall not exceed 150 foot-pounds.

(c) Handwheels:

- i. For above ground installations, including vaults.
- ii. Spoke type only. Webbed or disc type not allowed.
- iii. An arrow showing the direction to turn the handwheel to open the valve, with the word ‘OPEN’ in 1/2 in. letters in a break in the arrow shaft, shall be cast on the rim of the handwheel so as to be readily readable.
- iv. The maximum torque required to fully open or close the valve shall not exceed 80 foot-pounds.

(d) Valve Operating Nut Extension Shaft:

- i. All valves that have an operating nut at a depth greater than five (5) feet below finish grade shall have an operating nut extension shaft.
- ii. The shaft shall bring an operating nut to within 18 inches of finished grade. The operating nut extension shaft shall be made of similar material and size to the valve-operating shaft.
- iii. The extension shaft shall be permanently connected to the valve nut by drilling a hole through both pieces and inserting a fastening device, such as a grade-A bolt and nut.

5.6 Restraint

All fire hydrants, fire sprinkler connections, vertical bends, reducers, plugs, horizontal and vertical offsets, and 90°, 45°, and 22½° horizontal bends shall be restrained in accordance with the District detail “Length of Restrained Pipe”. All restraint assemblies shall be polyethylene wrapped. Refer to Sections 4.2 and 4.3 for more specific information.

5.7 Polyethylene Encasement

5.7.1 All polyethylene encasement material shall be manufactured in accordance with AWWA C105 for linear low density polyethylene film.

5.7.2 The polyethylene film shall meet the following AWWA C105 requirements:

Tensile Strength	3,600 psi, minimum
Elongation	800% minimum
Dielectric Strength	800 Volts/mil thickness, minimum
Thickness	8 mils, minimum

5.8 Thrust Blocks

5.8.1 Concrete thrust blocks, in addition to restraint, shall be installed at all tees, plugs, bends, and fire hydrants in accordance with the District details. Where thrust blocks are used to block fittings, the fitting shall be protected from concrete by an 8 mil thickness of polyethylene as a bond breaker. Care shall be taken not to block outlets or to cover bolts, nuts, clamps, or other fittings or to make them inaccessible.

5.8.2 Concrete for thrust blocks shall be in accordance with Section 5.10 of these specifications.

5.8.3 All forming for concrete thrust blocks and anchors will be done by bulk heading around the shape of the thrust blocks or anchor with wood, burlap, or reinforced paper sacks filled with sand or earth.

5.8.4 Wood forms shall be removed before backfilling.

5.8.5 Placing Concrete

- (a) Place concrete in accordance with ACI 301.
- (b) Notify Engineer minimum 24 hours prior to commencement of concrete operations.
- (c) Ensure reinforcement, inserts, embedded parts and formed joints are not disturbed during concrete placement.
- (d) Thrust blocks shall bear against undisturbed earth. When it is impossible, through over excavation or other cause, to pour a thrust block against undisturbed earth, harness cords shall be required to anchor the fittings to the main.
- (e) Minimum bearing surface area shall be as shown on the District detail.
- (f) A bond breaker shall be placed between the pipe and the kick block to aid in ease of future removal.
- (g) Newly placed concrete shall be allowed to cure for a minimum of 24 hours prior to backfill and compaction.
- (h) Maintain records of concrete placement. Record date, location, quantity, air temperature, and samples taken.

5.8.6 Curing and Protection

- (a) Immediately after placement, protect concrete from premature drying, excessively hot or cold temperatures, and mechanical injury.

1. Maintain concrete with minimal moisture loss at relatively constant temperature for period necessary for hydration of cement and hardening of concrete.

5.9 Pre-Cast Concrete Vaults

5.9.1 All butterfly valve manholes, air relief and vacuum valve vaults, pressure reducing valve vaults, master meter vaults, and other vaults shall be pre-cast concrete. Design of vaults shall be for H-20 traffic loading and shall include plastic manhole steps, cast iron rings and covers of a pattern approved by the District Engineer, with the word "WATER" cast thereon, sump pit (where specified by District details), and shall be in accordance with the District details.

5.9.2 Design Criteria:

Watertight precast reinforced air-entrained concrete structures designed to ASTM C890 AASHTO HS20 live loading and installation conditions, and manufactured to conform to ASTM C913.

Minimum 28-day Compressive Strength: 5,000 psi.

Minimum section wall thickness: 6-inches.

Minimum roof slab thickness: 8-inches.

Minimum floor slab thickness: 10-inches.

Sump dimensions: 24-inch diameter, 2'-6" deep.

Honeycombed or re-tempered concrete is not permitted.

5.9.3 Delivery, Storage and Handling:

- (a) Transport and handle precast concrete units with equipment designed to protect units from damage.
- (b) Do not place concrete units in position to cause overstress, warp or twist.

5.9.4 Materials

- (a) Portland Cement: ASTM C150, Type II
- (b) Coarse Aggregates: ASTM C33; Graded 1-inch to No. 4 Sieve
- (c) Sand: ASTM C33; 2.35 fineness modulus
- (d) Water: Potable; clean and free of injurious amounts of acids, alkalis, salts, organic materials, and substances incompatible with concrete or steel.
- (e) Air Entraining Admixtures: ASTM C260.
- (f) Reinforcing Steel:
 - i. Deformed Bars: ASTM A615/A615M, Grade 40.
 - ii. Welded Wire Fabric: ASTM A185.

(g) Joint Sealant:

i. ASTM C990

5.9.5 Mixes:

(a) Design concrete mix to produce required concrete strength, air-entrainment, watertight properties, and loading requirements.

5.9.6 Frames and Covers

(a) Frames and covers shall be cast iron in accordance with ASTM A48, Class 24, unless otherwise specified herein.

(b) 24-inch standard frame and cover: Weight: 400 pounds

i. Acceptable Manufacturers
Neenah Foundry Model R-1706
D&L Supply Model A-1161
Construction Castings Model J-1161

(c) 30-inch standard Frame and Cover: Weight: 600 pounds

i. Acceptable Manufacturer's
Neenah Foundry Model R-1798
D&L Supply Model A-1361
Construction Castings Model J-1361

(d) 24-inch Locking Frame and Cover: Weight: 450 pounds

i. Acceptable Manufacturer's
Neenah Foundry Model R-1916-F
D&L Supply Model A-1925
Construction Castings Model J-1925

(e) 24 x 36-inch Double Frame and Cover: Weight: 655 pounds

i. Acceptable Manufacturer's
Neenah Foundry Model R-1740-D2
D&L Supply Model A-1425
Construction Castings Model J-1425

(f) Cover Pattern: City of Denver, Colorado Standard.

(g) Lettering: Cover marked WATER with 1 1/8-inch letters, raised 1/8-inch for all covers.

(h) Lifting notch shall be pick hole type.

(i) All bearing surfaces shall be machined.

5.9.7 Access Steps

- (a) Copolymer Polypropylene plastic manhole step with ½-inch grade 60 steel reinforcement, only.
- (b) Maximum distance from ground surface to first step is 20-inches. Remaining steps are 12-inches apart on center.
- (c) Dimensions: Minimum width: 14-inches, Minimum cross section: 0.875-inches of solid material.
- (d) Install step a minimum of 3 3/8-inches in a preformed hole or cast-in-place as part of the manhole section.
- (e) Acceptable Manufacturers
M.A. Industries Model PS-2-PF

5.9.8 Vent Pipe

- (a) Vent Pipe: 6-inch diameter schedule 40 PVC. Horizontal section sloped to drain into vault.
- (b) Vent Pipe Cover: 8-inch outside diameter residential-style vent pipe, 20 gauge seamless aluminum body. 3-feet tall. Color: black. Per District detail 20W.
- (c) Alternate Vent Pipe Cover: 6-5/8-inch outside diameter galvanized steel schedule 40. 8-feet tall. Color: yellow with markings similar to marker post. Per District detail 21W. Alternate vent pipe cover may be required by the District under special circumstances.

5.9.9 Bedding Materials

- (a) 6-inches of 3/4-inch Crushed Rock Bedding under vault as specified in Trenching, Bedding and Backfill or as required by the Geotechnical Report/Engineer and/or the District Engineer.

5.9.10 Fabrication and Manufacture

- (a) Fabricate precast reinforced concrete structures in accordance with ASTM C913, to dimensions indicated on the drawings, and to specified design criteria.
- (b) Core holes for piping shall be cast smooth to accommodate Link-Seal(s)

5.9.11 Installation

- (a) Verify piping connection, size and location as indicated on the drawings.
- (b) Vaults shall be set plumb with a hoist truck or crane of sufficient size. Vaults shall be lifted by the cast in place lifting hooks.

5.10 Concrete Materials

5.10.1 Cement

- (a) All cement used shall be Type II Portland cement conforming to the requirements of ASTM C150.

5.10.2 Aggregates

- (a) Fine Aggregates: Fine aggregates shall consist of natural sand or a blend of natural sand and crushed sand provided the quantity of crushed sand is not more than 50% of the total sand by dry weight.
- (b) Coarse Aggregates: Coarse aggregates shall consist of gravel or crushed stone and shall conform to the grading and quality requirements of ASTM C33 for Size No. 467, No. 57, or No. 67. Nominal maximum size of coarse aggregate shall comply with ACE 318.
- (c) If the aggregates used are known to be reactive with high alkali cement, as determined by ASTM C295, or if the reactivity of the aggregate is not known, the use of low alkali cement is required to assure adequate protection from alkali aggregate reaction.

5.10.3 Water

- (a) The batch mixing water and mixer washout water shall conform to the requirements of ASTM C94.

5.10.4 Admixtures

- (a) Air Entrainment: An air-entraining agent shall be used in all concrete. The agent used shall be in accordance with ASTM C260 and shall be added to the batch in accordance with ASTM C94.
- (b) Chemical: Chemical admixtures that do not contain calcium chloride and that conform to ASTM C494 for concrete may be used. All chemical admixtures shall be compatible with the cement and all other admixtures in the batch.
- (c) Fly Ash: Fly ash may be used in the concrete mixes. Additions to the mix will be on a cement substitution basis. The fly ash shall conform to ASTM C618. Fly Ash content shall not exceed 20% by weight.

5.10.5 Class A Concrete (4,000 psi)--Encasements

- (a) Class A concrete shall be molded and cured in compliance with ASTM C31.
- (b) Class A concrete shall be used for structural concrete including piping encasements.

- (c) Class A concrete shall conform to the following requirements:

<u>Unit</u>	<u>Measurement</u>
Compressive Strength (28 day)	4,000 psi
Water/Cement Ratio	0.50 by weight (maximum)
Air Entrained	4 to 7 percent
Slump -	2 inches (minimum) 4 inches (maximum)

5.10.6 Class B Concrete (2,500 psi)—Thrust Blocks

- (a) Class B concrete shall be molded and cured in compliance with ASTM C31.
- (b) Class B concrete shall be used exclusively for thrust blocks.
- (c) Class B concrete shall conform to the following requirements:

<u>Unit</u>	<u>Measurement</u>
Compressive Strength (28 day)	2,500 psi
Water/Cement Ratio	0.63 by weight
Air Entrained	4 to 7 percent
Slump -	2 inches (minimum) 4 inches (maximum)

5.10.7 Flow Fill - (Low Strength Concrete)

- (a) Flow Fill or Flowable Concrete Backfill, shall be molded and cured in compliance with ASTM D4832.
- (b) Flow Fill shall be used in accordance with section 8, Trenching, Bedding, and Backfill and used as bedding and / or backfill only as directed by the District Engineer.
- (c) Flow Fill shall conform to the following requirements:

<u>Unit</u>	<u>Measurement</u>
Compressive Strength (28 day)	100 psi (minimum) 200 psi (maximum)
Air Entrained	5 percent
Slump -	6 inches (minimum) 8 inches (maximum)

- (d) Flash Fill may be used in place of flow fill with prior approval by the governing agency.

5.10.8 Concrete Reinforcement

- (a) All deformed reinforcing bars shall conform to ASTM A615, Grade 40 or 60.
- (b) All welded steel wire fabric shall conform to ASTM A185 except that the weld shear strength requirement shall be extended to include a wire size differential up to and including six gages.

5.10.9 Concrete Forms

- (a) Forms shall produce shapes, lines and dimensions of the concrete structures as shown on the drawings.
- (b) Forms shall be made of wood, metal or other acceptable material. The forms shall produce a smooth concrete finish to the tolerances described in ACI 301.
- (c) Forms shall be mortar tight and braced or tied to maintain its proper position and shape during and after concrete placement. Embedded metal ties with snap-off ends shall be used for internal form ties. Ordinary wire ties will not be allowed.
- (d) The Engineer, prior to pouring concrete, shall review forms.
- (e) Forms shall be removed in a manner that will insure the integrity of the structure and its surfaces.

5.10.10 Placing Concrete

- (a) Place concrete in accordance with ACI 301.
- (b) Notify Engineer minimum 24 hours prior to commencement of concrete operations.
- (c) Ensure reinforcement, inserts, embedded parts and formed joints are not disturbed during concrete placement.
- (d) Maintain records of concrete placement. Record date, location, quantity, air temperature, and samples taken.

5.10.11 Curing and Protection

- (a) Immediately after placement, protect concrete from premature drying, excessively hot or cold temperatures, and mechanical injury.
- (b) Maintain concrete with minimal moisture loss at relatively constant temperature for period necessary for hydration of cement and hardening of concrete.

5.11 Tracer wire and test stations

- (a) 12-gauge tracer wire with a 4-inch test station behind each fire hydrant shall be installed on all water line per District detail 8W.
- (b) The Contractor shall not "loop" tracer wire into valve boxes on the water main.
- (c) A continuity test shall be performed on the installed tracer wire at the Contractor's expense. A District representative must be present.

5.12 **Marker Posts**

- (a) Marker posts shall be installed to locate all valves on lines in easements or other rights-of-way when not at street intersections. Fire hydrant auxiliary valves shall not be marked unless specifically directed by the District.
- (b) Steel marker posts (per detail 35W) shall be installed unless otherwise approved by the District.

6. MECHANICAL WATER PIPING

6.1 General

6.1.1 All materials shall be new and unused.

6.1.2 Ductile Iron Pipe for Vaults, Pump Stations

- (a) Flanged ductile iron pipe shall conform to the requirements of AWWA C115.
- (b) Ductile iron pipe shall conform to the requirements of AWWA C151.
- (c) Required working pressure: 350 psi.
- (d) Special thickness class: 53
- (e) Pipe threads: Threads on the pipe barrel shall be taper pipe threads in accordance with ANSI B1.20.1.
- (f) External Coating: External pipe coating shall be an asphaltic coating approximately 1-mil thick.
- (g) Internal Lining: Pipe furnished shall have standard thickness cement-mortar lining in accordance with AWWA C104. Minimum standard thickness per AWWA C104 is as follows:

<u>Pipe and Fitting Size</u>	<u>Thickness of Linings</u>
3" – 12"	1/16"
14" – 24"	3/32"
20" – 42"	1/8"

- (h) Acceptable Pipe Manufacturers:

American Cast Iron Pipe
Atlantic States Cast Iron Pipe
Clow Water Systems
Griffin Pipe Products
McWane Cast Iron Pipe
Pacific States Cast Iron Pipe
United States Pipe and Foundry

6.1.3 Flanges

- (a) Ductile Iron flanges only. Cast Iron flanges not permitted.
- (b) Ductile iron threaded flanges shall conform to the requirements of AWWA C115.
- (c) Flanged fittings shall be manufactured in accordance with AWA C110 (3-inches through 48-inches) and AWWA C153 (54-inches through 64-inches)
- (d) Required working pressure: 250 psi.

- (e) Flange threads: All flanges shall have an internal taper pipe thread in accordance with ANSI B1.20.1.
- (f) Bolt circle and bolt holes shall match those of ANSI B16.1 Class 125.
- (g) Bolts and Nuts: Bolts shall conform to ANSI B18.2.1 and Nuts shall conform to ANSI B18.2.2 and per Appendix A, AWWA C115.
- (h) Gaskets: Synthetic rubber, either ring or full faced, 1/8-inch thick and per Appendix A, AWWA C115 for 250 psi working pressure.
- (i) Acceptable Manufacturers:

Tyler Pipe Industries
 Griffin Pipe Products
 United States Pipe and Foundry
 Union Foundry Company

6.1.4 Pipe Paint

- (a) Exterior pipe paint shall be applied to all mechanical piping and fittings.
- (b) Paint type: Alkyd (oil-based enamel). High gloss industrial enamel for surfaces in mild to moderately severe exposures.
- (c) Primer: Per manufacturer's recommendations.
- (d) Thickness: Per manufacturer's recommendations.
- (e) Acceptable Manufacturers:

Tnemec Hi-Build Tneme-Gloss Series 2H

- (f) Color shall be:

Potable water: Dark Blue SC06 Safety Blue

- (g) Pipe Painting
 - i. The Contractor shall be responsible for painting all new ferrous based pipe fittings, valves and appurtenances and for touching up any existing piping which has been marred, or scratched in the course of construction.
 - ii. Paint shall be applied to pipe that has been cleaned in accordance with SSPC-SP2 (hand tool cleaning) and primed. All chipped or damaged paint shall be re-primed. Paint shall be applied in two coats in accordance with the manufacturer's instructions.

6.1.5 Installation

- (a) Cut pipe ends square, bevel and de-burr as necessary.
- (b) Remove scale and dirt on inside and outside before assembly.

- (c) Installation of all Mechanical Water Piping, fittings and accessories shall be per the Manufacturer's recommendations.
- (d) Provide manufacturer's certification that materials meet or exceed minimum requirements as specified.
- (e) Coordinate dimensions and drilling of flanges with flanges for valves, pumps and other equipment to be installed in piping systems. Bolt holes in flanges to straddle vertical centerline.
- (f) Reject materials contaminated with gasoline, lubricating oil, liquid or gaseous fuel, aromatic compounds, paint solvent, paint thinner and acid solder.
- (g) Pipe-joint compound, for pipe carrying flammable or toxic gas, must bear approval of Underwriters' Laboratories or Factory Mutual Engineering Division.
- (h) Unless otherwise specified, pressures referred to in all Piping Sections are expressed in pounds per square inch gauge above atmospheric pressure (psig) and all temperatures are expressed in degrees Fahrenheit.

6.1.6 Materials and Equipment

- (a) The use of manufacturer's name and/or model number is for the purpose of establishing the standard of quality and general configuration desired.
- (b) Equipment shall have the name of the maker, nominal size, flow directional arrows (if applicable), working pressure for which they are designed and standard referenced specifications cast in raised letters or indelibly marked upon some appropriate part of the body.
- (c) Unless otherwise noted, fittings shall have a minimum working pressure of 200 psi or be of the same working pressure as the pipe they connect to, whichever is higher and suitable for the pressures noted where they are installed.
- (d) Unions: brass or bronze unions for joining nonferrous pipe; malleable brass or bronze-seated iron or steel unions for joining ferrous pipe.
- (e) Dielectric Connectors
 - i. Dielectric pipe fittings/insulators and unions shall be used to prevent galvanic action wherever valves or piping of dissimilar metals connect. This shall be particularly the case for copper, brass and bronze piping connecting to cast iron or steel piping systems.
 - ii. Dielectric unions shall be used for 2-in and smaller connections. Steel union nuts shall meet ASTM A575 requirements. The steel or ductile iron connection end shall have a steel body and shall have accurately machined taper tapped pipe threads in accordance with ANSI B2. 1. The copper connection end shall be a copper solder joint that meets requirements of ASTM B88. Dielectric unions shall be rated for at least 250 psi at 210 degrees F.

- iii. Dielectric flange unions shall be used for connections 2-1/2-in and larger. Cast iron flanges shall meet ASTM A126; the copper solder end shall meet ASTM B62 and the pipe thread shall meet ANSI B2. 1. Dielectric flange unions shall be rated for at least 175 psi at 210 degrees F.
 - iv. Dielectric unions and flange unions shall be as manufactured by Epco Inc., Cleveland, OH or equal.
 - v. Flange Insulation Kits, Type E shall be used to control losses due to corrosion.
 - vi. Insulated sleeve couplings and flange adaptors shall be similar to those units as specified elsewhere.
- (f) Plugs and Caps
- i. Provide standard plug or cap as required for testing; plugs, caps suitable for permanent service.
 - ii. Plug, cap or otherwise cover all piping work in progress.
- (g) Miscellaneous Adaptors

Between different types of pipe and/or fittings, special adapters may be required to provide proper connection. Some of these may be indicated on the Drawings or specified with individual types of pipe or equipment. However, it is the Contractor's responsibility to ensure proper connection between various types of pipe, to structures and between pipe and valves, gates, fittings and other appurtenances. The Contractor shall provide all adapters as required, whether specifically noted or not.

(h) Bolted Sleeve-Type Couplings

- i. Couplings shall be in accordance with AWWA C219 and shall be of a gasketed, sleeve type, with diameter to fit the pipe. Couplings shall consist of one steel middle ring, 2 steel followers, 2 rubber compound wedge section gaskets and sufficient bolts to compress the gaskets.
- ii. Couplings: Cast-iron in accordance with ASTM A48 or A126, Class B or Ductile-iron in accordance with ASTM A536.
- iii. Flanges: Steel plate. Dimensions and finish in accordance with AWWA C207.
- iv. Gaskets: Crude or synthetic rubber base compound.
- v. Nuts and Bolts:
 - 1. Provide bolts and bolt-studs in accordance with ASTM A307 and ANSI B 1.1 with hexagonal or square heads, coarse thread fit, threaded full length with ends chamfered or rounded.
 - 2. Project ends 1/4-in beyond surface of nuts.

3. Hexagonal nuts with dimensions in accordance with ANSI B 18.2 and coarse threads in accordance with ANSI B 1.1.
- vi. Middle Ring and Followers: Thickness at least equal to that specified for size of pipe on which coupling is to be used and shall not be less than 10-in long for pipe 30-in and larger and not less than 7-in long for pipe under 30-in in diameter.
 - vii. Acceptable Manufacturers:

Smith-Blair	Model 411
Dresser	Model 138-38
Romac	Model 501
Ford	Model FC1
Baker	Model 228
- (i) Harnessing and Restraint
 - i. Where harnessed couplings or adapters are noted, they shall conform to AWWA Manual M1 except as modified by the Drawings or this Specification.
 - ii. Unless otherwise noted, size and material for tie rods, clamps, plates and hex nuts shall be as shown on the Drawings, or, if not shown on the Drawings, shall be as required in AWWA Manual MI 1. Manufactured restraining clamp assemblies shall be as manufactured by Stellar Corporation, Columbus, OH, or fabricated equal.
 - iii. Flange Coupling Adaptors:

Flange coupling adaptors may be used in lieu of threaded or welded flange spool pieces on plain end ductile iron pipe as directed by the engineer. Flange Adaptors shall be MegaFlange Series 2100 as manufactured by EBAA Iron Sales, Inc. or approved equal.
 - (j) Copper Tubing: shall conform to ASTM B88 type K.
 - (k) Pressure Gauges
 - i. Bosses, connections, or nipples for gauges shall be provided as acceptable to the Engineer. Unbossed tappings shall not be acceptable.
 - ii. Gauges shall be furnished as part of a complete factory assembly, including gauge, snubber, liquid fill, bar stock ball valve isolation valve and threaded red brass connecting piping.
 - iii. Unless otherwise noted, gauge rating shall be from 0 to at least 2.5 percent higher than the rating of the pipe it is connected to.
 - iv. For Liquid Service
 1. Pressure gauges shall have a 300 series stainless steel/ABS or FRP/Aluminum case and shall be 4-in nominal diameter with a full-sized

Type 316 stainless steel Bourdon tube and a 300 series stainless steel movement. The gauges shall be liquid filled with glycerin and shall be provided with a filler/breather cap. The socket shall be 1/4-in NPT Type 316 stainless steel with a bottom connection and the dial shall be a white background with black markings. Gauges shall be ANSI Grade A plus or minus 1 percent of scale and shall have a blow-out back design.

2. Gauges for the above services shall be Model 344Y liquid filled as manufactured by Crosby Valve & Gauge Co., or equal by U.S. Gauge; Ashcroft or Trerice.

v. Gauges shall be furnished from standard ranges of the manufacturer, with dual range (ft and psi) scales as indicated on the drawings.

(l) Wash Hose Station

i. Shall be 3/4-in, single supply, hose station complete as shown on the Drawings.

ii. Hose shall be 3/4-in equal to Boston Hose Co. Figure No. 457.

iii. Hose nozzle shall be lever operated, encased in rubber equal to Straham No. 70.

iv. Globe valves shall be 150 pounds with Teflon disc equal to Hammond Figure No. 1 B4 1 3T. Check valves shall be bronze swing checks equal to Hammond Figure No. 1B942.

v. Serrated hose connections shall be brass or bronze, a minimum of 3-in long. Secure hose with double stainless steel bands at each connection.

vi. Pipe hanger shall be copper plated malleable iron split ring type with malleable iron wall plate to receive 3/8-in diameter threaded rod.

vii. Wall anchors for hose rack shall be 5/16-in threaded stainless steel anchors with 5/16-in stainless steel hex bolts.

viii. Assembly shall be as provided by Joseph A. Pink & Son, Inc., Model No. CD-102-B; Leonard Valve Company, Model No. L-SHR-50-.75-N-2 or equal.

(m) Appurtenances and Miscellaneous Items

i. All gaskets, glands, bolts, nuts and other required hardware shall be provided for connection of piping and appurtenances. Bolts and nuts shall be high strength, Type 316 stainless steel if submerged, buried, or subject to splashing and cadmium plated otherwise, with tee-head and hexagon nut. All other hardware shall be of the size, type and number as required and recommended by the piping or appurtenance manufacturer and as specified herein.

ii. All gaskets for flanges shall be full face and suitable for 200 degrees F operating temperature, and the fluids carried. See also Division 1.

- iii. Plugs, caps and similar accessories shall be of the same material as the pipe and of the locking type, unless otherwise noted.
- iv. Unions shall be of the same material as the pipe, except for dielectric connections.
- v. Special protective tape shall be fabric reinforced petroleum tape as manufactured by Denso Inc., Houston, TX or equal.

(n) Floor Drains

- i. Floor drains shall have an 8-inch circular opening and an outlet connection for 4-in schedule 40 PVC pipe except where required by other type pipe and/or indicated on the Drawings. They shall be Model No. R-4937-B as manufactured by Neenah or equal.

(o) Pipe Penetration Seals

- i. Seals shall be modular mechanical type, consisting of interlocking synthetic rubber links shaped to continuously fill the annular space between the pipe and wall opening.
- ii. Links shall be loosely assembled with bolts to form a continuous rubber belt around the pipe with a pressure plate under each bolt head and nut.
- iii. Pipe penetration seals shall be Link Seal as manufactured by Thunderline Corporation, Belleville, MI.

7. ENCASEMENT AND CASINGS

7.1 Concrete Encasements

Concrete encasements shall be installed with prior approval by the District Engineer under the following conditions:

- Where water lines are at a depth too shallow to sustain traffic load or any other loads to which they are subjected.
- At all locations where the water main may be subjected to freezing. At these locations, the pipe shall be wrapped in approved insulating material prior to encasement.
- At locations where horizontal movement of the water mains may be experienced, i.e. below streambeds. The limits of concrete encasement shall be used until a minimum of five feet (5') of cover is obtained.
- At sanitary sewer crossings where the minimum vertical clearance of 18" cannot be achieved.
- At any location designated by the District or District Engineer.

7.1.1 Concrete--Refer to Section 5.10, "Concrete Materials." Use Class A concrete for encasements.

7.1.2 Concrete Reinforcement--Refer to Section 5.10, "Concrete Materials."

7.1.3 Concrete Forms--Refer to Section 5.10, "Concrete Materials."

7.1.4 Placing Concrete--Refer to Section 5.10, "Concrete Materials."

7.1.5 Curing and Protection--Refer to Section 5.10, "Concrete Materials."

7.2 Pipe Casings

Pipe casings shall be used where bores are required under special rights-of-way by the approving agency. All pipe casings shall be constructed to conform to the appropriate District details.

7.2.1 **Design Requirements**

- (a) Design casing pipe of leak proof construction. Design for earth and other pressure present plus highway H2O loading with associated recommended impact loading.
- (b) Highway Crossings: Design tunnel for earth and other pressure loads present, plus AASHTO H2O live loading.
- (c) Design bracing, backstops, and use jacks of sufficient rating for continuous jacking without stoppage, except for adding pipe sections and as conditions permit, to minimize tendency of ground material to "freeze" around casing pipe.

7.2.2 Quality Assurance

- (a) Perform work in accordance with Construction Drawings, Colorado Department of Transportation standards, NUCA Trenchless Excavation Construction Equipment & Methods Manual, NUCA Pipe Jacking & Microtunneling Design Guide.

7.2.3 Qualifications

- (a) Design pipe jacking installation and load bearing work under direct supervision of Professional Engineer experienced in design of this Work and licensed in State of Colorado.

7.2.4 Delivery, Storage and Handling

- (a) Provide temporary end caps and closures on piping and fittings, maintain in place until installation.
- (b) Protect piping from entry of foreign materials and water by temporary cover, and isolating parts of completed system.
- (c) Use wooden shipping braces between layers of stacked pipe. Stack piping lengths no more than 3 layers high.
- (d) Support casing and carrier pipes with nylon slings during handling.

7.2.5 Casing and Jacking Pipe Materials

- (a) Steel Casing Pipe: ASTM Z53, Grade B, 35,000 psi minimum yield strength, minimum wall thickness as indicated on District details 38W and 39W, full circumference welded joints in accordance with AWS D1.1 to withstand excavation forces.
- (b) Minimum Diameter: per District details 38W and 39W.

7.2.6 Casing Spacers

- (a) Restrained Casing Spacers for Pressure Pipe
 - i. PVC Pipe and Ductile Iron Pipe applications
 - ii. Band: 14 gauge, hot rolled, pickled and oiled Steel
 - iii. Risers: 10 gauge, hot rolled, pickled and soiled Steel
 - iv. Runners: Ultra High Molecular Weight Polymer
 - v. Configuration: Refer to Construction Drawings
 - vi. Acceptable Manufacturers: Advance Products & Systems, Inc.
- (b) Restrained joint pipe with non-restrained casing spacers may be used with prior approval by the District.

7.2.7 Preparation

- (a) Identify required lines, levels, contours, and datum locations.

- (b) Locate, identify and protect utilities indicated to remain in service from damage or exposure.
- (c) Protect plant life, lawns, and other features remaining as portion of final landscaping.
- (d) Protect bench marks, survey control points, existing structures, fences, sidewalks, paving, and curbs from excavating equipment and vehicular traffic.
- (e) Establish minimum horizontal separation of 10-feet from other utilities or as indicated on the drawings.

7.2.8 Jacking and Receiving Pits

- (a) Excavate pits in accordance with installation plan and as site conditions require.
- (b) Ensure casing entrance face as near perpendicular to alignment as conditions permit.
- (c) Establish vertical entrance face at least 1 foot above top of casing.
- (d) Install dewatering measures and excavation supports.

7.2.9 Casing Pipe Installation

- (a) Boring:
 - i. Push pipe into ground with boring auger rotating within pipe to remove spoil. Do not advance cutting head ahead of casing pipe except for the distance necessary to permit cutting teeth to cut clearance for pipe. Arrange machine bore and cutting head to be removable from within pipe. Arrange face of cutting head to provide barrier to free flow of soft material.
 - ii. When unstable soil is encountered during boring retract cutting head into casing to permit balance between pushing pressure and ratio of pipe advancement to quantity of soil.
 - iii. When voids develop greater than outside diameter of pipe by approximately one inch, grout to fill voids.
 - iv. When boring is obstructed, relocate, jack, or tunnel as directed by the Engineer.
- (b) Jacking
 - i. Construct adequate thrust wall normal to proposed line of thrust.
 - ii. Impart thrust load to pipe through suitable thrust ring sufficiently rigid to ensure uniform distribution of thrust load on full pipe circumference.
- (c) Drilling and Jacking
 - i. Use oil field type rock roller bit or plate bit made up of individual roller cutter units solidly welded to pipe which is turned and pushed for its entire length by drilling machine to give bit necessary cutting action.
 - ii. Inject high density slurry (oil field drilling mud) to head as cutter lubricant. Inject slurry at rear of cutter units to prevent jetting action ahead of pipe.

- (d) Mining and Jacking: Utilize manual hand mining excavation from within casing pipe as casing is advanced with jacks, allowing minimum ground standup time ahead of casing pipe.

7.2.10 Pressure Grouting

- (a) Pressure grout annular space between casing pipe and surrounding earth.

7.2.11 Carrier Pipe Installation

- (a) Clean, inspect, and handle pipe
- (b) Place carrier pipe. Exercise care to prevent damage to pipe joints when carrier pipe is placed in casing.
- (c) Support pipeline within casing so no external loads are transmitted to carrier pipe. Attach supports to barrel of carrier pipe; do not rest carrier pipe on bells.
- (d) Install Link-Seal or approved equal in annual space to seal carrier pipe in casing. Install neoprene boot end seal at each end of casing to carrier pipe.

7.2.12 Tolerances

- (a) The pipe shall be installed so as to insure a smooth, continuous and uniform casing.
- (b) During and after installation, no point along the length of the casing shall lie more than 6-inches from the vertical and horizontal alignment indicated on the plans.
- (c) There shall be no angle point or deflection in the casing greater than one (1) degree.

7.2.13 Field Quality Control

- (a) Inverts of the casing pipe shall be surveyed by the Surveyor and approved prior to installation of the carrier pipe. The Contractor will be required to provide access to the casing pipe inverts for survey.

8. TRENCHING, BEDDING, AND BACKFILL

8.1 Trenching

8.1.1 General

- (a) Excavation for pipelines, fittings, and appurtenance shall be open trench to the depth and in the direction necessary for the proper installation of the same as shown on the approved drawings or as otherwise approved by the District Engineer.
- (b) Any water which may be encountered or may accumulate in the excavation shall be pumped out or otherwise removed as necessary to keep the bottom of the excavation free and clear of water during the progress of the work. Refer to Section 8.2.8, Dewatering.
- (c) Grading and Stockpiling – The contractor shall control grading in a manner to prevent water from running into excavations. Obstruction of surface drainage shall be avoided and means shall be provided whereby storm and wastewater can be uninterrupted in existing gutters, other surface drains or temporary drains.

8.1.2 Procedure

- (a) All existing asphalt or concrete surfacing shall be saw cut vertically in a straight line, and removed from the jobsite prior to starting the trench excavation. This material shall not be used in any fill or backfill.
- (b) Remove lumped subsoil and rock up to ½ cu yd, measured by volume. Remove larger material and dispose.
- (c) Do not advance open trench more than 400 feet ahead of installed pipe. The trench shall not be backfilled until the Engineer reviews the pipe and bedding installation.
- (d) Trench width shall not be more than 16-inches nor less than 12-inches wider than the outside diameter of the pipe for proper placement and densification of the bedding and backfill material and assembly of pipe and appurtenances.
- (e) Excavate trenches to depth indicated on Drawings. Provide uniform and continuous bearing and support for bedding material and pipe.
- (f) Provide trench stabilization and support per applicable regulations.
- (g) Trim excavation. Hand trim for bell and spigot pipe joints to provide continuous support of pipe in trench. Remove loose matter. Do not rest pipe on bells.
- (h) Excavated material shall not be placed closer than 2-feet from the top edge of the trench. Heavy equipment should not be used, or placed, near the sides of the trench unless the trench is adequately braced.
- (i) Surplus Excavation Material: All surplus excavation shall be removed from the jobsite and disposed of properly. If the surplus excavation is disposed of on

private property, written permission shall be obtained from the property owner and a copy given to the Engineer.

8.1.3 Safety Precautions

- (a) All excavations shall be performed, protected and supported as required for safety and in the manner set forth in the operation rules, orders and regulations.
- (b) Prepare excavation protection plan (for 20 foot cuts and deeper) under direct supervision of Professional Engineer experienced in design of this Work and licensed in the State of Colorado.
- (c) Bracing Excavations
 - i. All excavations shall be properly supported in the manner as required by Occupational Safety and Health Administration or as required by State laws and Municipal ordinances and as may be necessary to protect life, property or the work.
 - ii. Excavations shall be so braced, sheeted and supported that they will be safe, and the ground alongside the excavation will not slide or settle. Excavation shall be so braced or sheeted so as to provide conditions under which workmen ay work safely and efficiently at all times.
 - iii. The sheeting, shoring and bracing shall be so arranged as not to place any stress on portions of the completed work until the general construction thereof has proceeded far enough to provide ample strength.
 - iv. Care shall be exercised in the drawing or removing of sheeting, shoring, bracing and timbering to prevent the caving or collapsing of the excavation faces which are being supported and to prevent damage to completed work.

8.2 Bedding

8.2.1 General

- (a) Furnish all bedding material from a single source throughout the work unless otherwise approved.
- (b) Standard Bedding: Limits of bedding material shall be from 6-inches below the bottom of the pipe to 12-inches above the top of the pipe.
- (c) Bedding shall be compacted by vibrating, tamping, or a combination thereof, to 70% relative density for well-graded sand or squeegee material as determined by ASTM D 4253 and D 4254.
- (d) Special Bedding: Per district Detail 3W. Geotextile Fabric shall be installed with Class B Bedding per the District details.

8.2.2 Clean, free draining, well-graded sand or squeegee sand (Class A)

Well-Graded Sand

<u>Sieve Size</u>	<u>Percent Passing</u>
3/8 inch	100
No. 4	70 to 100
No. 8	36 to 93
No. 16	20 to 80
No. 30	8 to 65
No. 50	2 to 30
No. 100	1 to 10
No. 200	0 to 5

Squeegee Sand

<u>Sieve Size</u>	<u>Percent Passing</u>
3/8 inch	100
No. 200	0 to 5

8.2.3 3/4-Inch Crushed Rock Bedding (Class B)

- (a) 3/4-inch Crushed Rock Bedding shall be used for all pipelines at depths greater than 15 feet, for installation of all precast concrete vaults, and for installations requiring special bedding per District detail 3W, unless otherwise indicated on the drawings.
- (b) Clean, crushed aggregate, conforming to ASTM D448, No. 67:

<u>Sieve Size</u>	<u>Percent Passing</u>
1 inch	100
3/4 inch	90 to 100
3/8 inch	20 to 55
No. 4	0 to 10
No. 8	0 to 5

8.2.4 Flow Fill

Only as directed by the District Engineer. Refer to Section 5.10.

8.2.5 Geotextile Fabric

- (a) Non-woven, non-biodegradable, needle punched geotextile comprised of polypropylene fibers.

Apparent Opening Size	70	U.S. Sieve
Permittivity	1.8	sec ⁻¹
Permeability	0.26	cm/sec
Flow Rate	135	gal/min/ft ²
Grab Tensile Strength ¹²⁰	lbs	
Grab Tensile Elongation	50	%
Trapezoid Tear Strength	50	lbs
Mullen Burst Strength	240	psi
Puncture	70	lbs

- (b) Acceptable Manufacturers:
TC Mirafij; Model 140N

8.2.6 Foundations in Poor Soil

If excessively wet, soft, spongy, unstable or similarly unsuitable material is encountered at the surface upon which the bedding material is to be placed, the unsuitable material shall be removed to a depth as determined in the field by the District and in accordance with District detail 3W.

8.2.7 Stabilization Rock

- (a) Stabilization Rock shall be used in areas of unstable subgrade.
- (b) Uniformly graded rock ranging from ¾ inch to 1-½ inch.

<u>Sieve Size</u>	<u>Percent Passing</u>
2 inches	100
¾ inch	0 to 10

8.2.8 Pipe Clearance in Rocks

Ledge rock, boulders and large stones shall be removed to provide a clearance of at least 6" (six inches) below and on the side of the pipe and fittings.

8.2.9 Dewatering

- (a) Trenches shall be kept free from water during pipe laying. Method of dewatering shall provide for a completely dry foundation at the final lines and grades of the excavation.
- (b) Dewatering shall be accomplished by the use of sump pumps or well points. All water shall be disposed of in a suitable manner without being a menace to public health or causing public inconvenience in accordance with all applicable permits.
- (c) Dewatering operation shall continue until it is safe to allow the water table to rise in the excavations. Pipe trenches shall contain enough bedding and backfill to prevent flotation of the pipe.
- (d) Comply with Colorado Department of Public Health and Environment, Water Quality Control Division and local City and County requirements.
- (e) It is the Contractor's responsibility to obtain all necessary Storm Water Discharge Permits.

8.2.10 Bedding Procedure

The pipe shall be carefully bedded as shown in the District Bedding Details. The Contractor shall be responsible for accurately shaping the pipe subgrade to fit the bottom of the pipe for the width shown on the bedding details.

Each joint shall be recessed in bedding material as required by the bedding detail in such a manner as to relieve the bell or coupling of the pipe of all load and to insure continuous bearing along the pipe barrel upon the pipe subgrade.

8.3 Backfill

- 8.3.1 All trenches shall be backfilled after pipe, fittings and appurtenances have been installed, reviewed and accepted by the District. Bedding shall be installed in accordance with Section 8.2.
- 8.3.2 Whenever a compaction requirement is specified herein, the optimum moisture content and **Standard Proctor density** shall be determined in accordance with ASTM D-698.
- 8.3.3 Backfill shall be compacted by vibrating, tamping, or a combination thereof, to 90% of maximum dry density for cohesive soils in easements or open space outside of right-of-ways and 95% of maximum dry density for cohesive soils in right-of-ways as determined by ASTM D698 or as required by the governing authority.
- 8.3.4 Compaction shall be done by use of vibratory equipment, tamping rollers, pneumatic tire rollers or other mechanical tampers of the type and size approved by the District Engineer.
- 8.3.5 Employ placement method that does not disturb or damage the pipe or its coating and shall be kept as close to the pipe laying operation as practical.
- 8.3.6 Any damage to the pipe as a result of Contractor's operation shall be repaired and/or replaced.
- 8.3.7 The backfill shall be placed in horizontal layers of such depths as are considered proper for the type of compacting equipment being used in relation to the backfill material being placed.
- 8.3.8 Backfilling shall be accomplished in the zone in layers not to exceed 3' (three feet).
- 8.3.9 All backfill material shall be subject to the approval of the District.
- 8.3.10 Each layer shall be evenly spread, properly moistened and compacted to the specified density in Section 8.3.3.
- 8.3.11 Backfill trenches to contours and elevations as indicated on the drawings.
- 8.3.12 Backfilling procedures shall conform to the additional requirements, if any, of the appropriate agencies or private right-of-way agreements.

8.3.13 Import Backfill

- (a) Material of perishable, spongy, frozen, or otherwise improper nature shall not be used in backfilling, and no material greater than 4" (four inches) in any dimension shall be placed within 1' (one foot) of any pipe, manhole or structure.
 - (b) If the excavated material is not suitable for backfill, as determined by the Engineer, suitable backfill material shall be hauled in and utilized, and the rejected material hauled away and disposed of properly.
 - (c) The removal and replacement limits and quantity of import backfill material shall be coordinated and accepted by the District Engineer and governing authority prior to proceeding with the installation.
 - (d) All excess import or on-site backfill shall be hauled away and disposed of properly.
- 8.3.14 **Flow Fill:** Only as approved by the District Engineer. Refer to Section 5.10.

8.4 Compaction Testing

8.4.1 Frequency

(a) At a minimum, frequency of compaction testing shall comply with the following:

- Within Right-of-Ways: Per State, County and / or City requirements.
- Outside Right-of-Ways and within easements:

One test per lift per 250 feet of trench or 250 cubic yards of fill material, whichever controls.

One test at each vault, valve box, and service connection.

(b) Testing at Various Depths. Test from 1-foot below surface grade to no deeper than 2-feet above the pipe.

8.4.2 Procedure

- (a) As required by the District, compaction tests will be taken by an approved testing laboratory at locations designated by the District.
- (b) All expenses involved in these tests will be borne by the Developer/Owner.
- (c) Copies of test results will be forwarded to the District Engineer.
- (d) In all cases where the tests indicate compaction less than that required in these specifications, additional compaction and tests will be required until these specifications are met.
- (e) Final acceptance of the lines by the District will be contingent upon satisfactory results.
- (f) No hydrostatic testing of the water main will be allowed until satisfactory compaction is obtained.

8.5 Final Cleanup

8.5.1 After backfill and compaction has been completed, the right-of-way shall be dressed smooth and left in a neat and presentable condition to the satisfaction of the District and City/County.

9. INSTALLATION OF WATER MAINS

9.1 General

All pipe shall be laid without break from fitting to fitting. Pipe shall be laid to the line and grade as shown on the approved plans and in such a manner as to form a close concentric joint with the adjoining pipe and prevent sudden offsets of the line. Where possible, vertical deflections shall be made at pipe joints and vertical bends shall be eliminated. Permissible joint deflections are specified in Section 9.2.6. The interior of the water pipe shall be cleaned of all dirt and superfluous material of all description as work progresses.

At all times when pipe laying is not in progress, the open end of the pipe shall be closed with a tight fitting cap or plug to prevent the entrance of foreign matter into the pipe. These provisions shall apply anytime the work is unattended.

9.2 Alignment and Grade

9.2.1 Contractor shall install pipe to lines and grades as indicated on the plans. Contractor shall notify the District Engineer of any deviations for review and acceptance.

9.2.2 Whenever obstructions not shown on the plans are encountered during the progress of the work and interfere to such an extent that an alteration in the approved plans is required, the design engineer shall submit a revised plan to the District.

9.2.3 **Minimum Depth of Cover**

Minimum depth of cover over the pipe measured from final grade to the top of the pipe shall be 5 feet. Deviations from said depth of cover over the pipe shall be approved by the owner.

9.2.4 **Horizontal Clearance**

Maintain all water lines a minimum of 10 feet horizontal from other utilities, unless otherwise indicated on the plans.

9.2.5 **Vertical Clearance**

Maintain all water lines a minimum of 18 inches vertical from other utilities, unless otherwise indicated on the plans.

9.2.6 **Permissible Deflection at Joints and Fittings**

Install pipe to allow for expansion and contraction without stressing pipe, joints, or fittings.

Ductile Iron Pipe: Maximum deflection of joints shall not exceed AWWA C600 requirements as listed below:

DUCTILE IRON PIPE

Pipe Size	Maximum Deflection	Min. Radius of Curvature	
		L=18'	L=20'
3" – 12"	5°	205'	230'
14" – 42"	3°	340'	380'

PVC pipe: PVC pipe may not be installed on a curved alignment/grade or deflected at joints. High-deflection couplings are not permitted. Fittings and bends (MJ Fittings) that allow additional joint offset shall be used to achieve gradual alignment/grade changes with PVC pipe.

MJ Fittings: Maximum deflection at MJ fittings shall not exceed AWWA C600 requirements as listed below:

MJ FITTINGS

Pipe Size	Maximum Deflection	Min. Radius of Curvature	
		L=18'	L=20'
3" – 4"	8°	125'	140'
6"	7°	145'	160'
8" – 12"	5°	195'	220'
14" – 16"	3.5°	285'	320'
18" – 20"	3°	340'	380'
24"	2°	450'	500'

9.3 Laying of Pipe

9.3.1 Lowering of Water Main Material into Trench

Proper implements, tools and equipment satisfactory to the District Engineer shall be provided and used by the Contractor for the safe and convenient performance of the work. All pipe, fittings, valves and hydrants shall be carefully lowered into the trench piece by piece in such a manner as to prevent damage to the water main materials and protective coatings and linings. Under no circumstances shall water main materials be dropped or dumped into the trench.

If damage occurs to any pipe, fittings, valves, hydrants or water main accessories in handling, the damage shall be immediately brought to the District Engineer's attention.

9.3.2 Examination Before Installation

All pipe and fittings shall be carefully examined for cracks and other defects while suspended and before installation. Defective pipe or fittings shall be laid aside for review by the District.

9.3.3 Cutting of Pipe

The cutting of pipe for inserting valves, fittings or closure pieces shall be done in a neat and workmanlike manner without damage to the pipe or cement lining and so as to leave a smooth end at right angles to the axis of the pipe.

9.3.4 Bell or Coupling Ends to Face Direction of Laying

Pipe shall be laid with the bell or coupling ends facing in the directions of laying, unless otherwise specified by the District. Where the pipe is laid on a grade of 10% or greater, the laying shall proceed upward with the bell or coupling ends of the pipe upgrade, if the progression of work allows.

9.3.5 Jointing Push-on Joint Pipe

Cleaning and Assembly of Joint – The inside of the bell or coupling and the outside of the spigot end shall be thoroughly cleaned out remove oil, grit, excess coating and other foreign matter. The circular rubber gasket shall be flexed inward and inserted in the gasket recess of the bell socket.

A thin film of gasket lubricant shall be applied to either the inside surface of the gasket or the outside of the spigot end of the pipe or both. Gasket lubricant shall be supplied by the pipe manufacturer and accepted by the Engineer.

9.3.6 Permissible Deflection at Joints

Wherever it is necessary to deflect the pipe from a straight line, either in the vertical or horizontal plane, to avoid obstructions or plumb stems or where long-radius curves are permitted, the amount of deflection allowed shall not exceed that specified in Section 9.2.6.

9.3.7 Polyethylene Encasement

Install polyethylene encasement (8 mils thickness) on all ductile iron pipe and fittings in accordance with AWWA C105 and the District detail.

9.3.8 Tracer Wire

Tracer wire is required on all new water lines, regardless of pipe type. Refer to Section 5.11.

9.3.9 Insulation Between Different Metallic Pipe Materials

Whenever it is necessary to join pipe or fittings with dissimilar metal, a method of insulating against the passage of electric current shall be provided and shall be submitted to the District for approval prior to installation.

9.3.10 Setting of Fittings

Fittings shall be joined to pipe in the manner specified herein for cleaning, laying and joining pipe.

9.4 Installation of Water Line Appurtenances

9.4.1 Valves

- (a) Install in accordance with Manufacturer's instructions and as indicated on the drawings.
- (b) Install valves with stems upright or horizontal, not inverted.
- (c) Protect all bolts with corrosion resistant paint for above ground applications.
- (d) Test that valves open and close smoothly with operating pressure on one side and atmosphere pressure on the other, in both directions for two-way valve applications.
- (e) Buried installations:
 - i. Install in the closed position.
 - ii. Support valve in trench to prevent settling and excessive strain on the connection to the pipe.
 - iii. Install polyethylene encasement in accordance with AWWA C105.

- iv. Place valve boxes directly over valves with top of box being brought to surface of finished grade or as indicated on the drawings.
- v. After installation, carefully backfill and compact on each side of valve box per Section 8.

9.4.2 Valve Boxes and Valve Vaults

- (a) A valve box or valve vault shall be provided for every valve.
- (b) A valve box shall be provided for every valve that has no gearing or operating mechanism or in which the gearing or operating mechanism is fully protected with a cast iron grease case. All gate valves and butterfly valves 20" (twenty inches) and less shall have valve boxes and all butterfly valves larger than 20" (twenty inches) shall have concrete manholes to house the operator. Refer to Section 5.5.1 for valve box specifications.
- (c) Pressure reducing valves, check valves, and air relief and vacuum breaker valves shall be installed in concrete vaults. Manholes may be used with prior approval by the District.
- (d) The valve box shall not transmit shock or stress to the valve and shall be centered and plumb over the wrench nut of the valve, with the box cover flush with the surface of the finished pavement or embedded in an 18" (eighteen inch) square by 6" (six inch) thick concrete pad when placed in an area that is not paved.
- (e) A concrete vault shall be provided for all butterfly valve operators over 20" (twenty inches) per Section 5.9. The valve nut shall be readily accessible for operation through the opening in the vault, which shall be set flush with the finished surface of the pavement, or shall extend 6" (six inches) above grade in unpaved areas and have a concrete collar around the valve box.

9.4.3 Geotextile Fabric

- (a) Cover granular material with non-woven geotextile prior to backfilling where required by District details. Refer to Section 8.2.5.

9.4.4 Valve Markers

- (a) All valves installed on the main transmission lines shall be identified with a 3" (three inch) steel post marker offset as directed by the District Engineer and painted yellow, with the distance to the valve and the desired initials stenciled in black. Refer to detail 35W.
- (b) Where the valve is to be installed in a vault equipped with a vent pipe, the vent pipe will serve as a valve marker.
- (c) With prior approval by the District, a carsonite marker or redwood marker may be installed in lieu of steel markers. Refer to details 36W and 37W.

9.4.5 Dead Ends

- (a) All dead ends shall be closed with ductile iron or cast iron plugs which shall be restrained to the main and provided with a thrust block per Section 5.8. Blow-off assemblies shall be located as specified in Section 5.4.

9.4.6 2" Blowoff Assemblies

(a) Installation

- i. Excavate pipe trench in accordance with Section 8, Trenching, Bedding and Backfill.
- ii. Clean interior and exterior surfaces of all pipe and fittings.
- iii. Install blow-off assembly according to District detail 13W.
- iv. Install blow-off assembly facing away from sanitary sewer, where possible.
- v. Avoid installing blow-off assembly in concrete curb and gutter, cross pans, etc.
- vi. All pipe, fittings, and materials must be new.
- vii. Water main plug must be a center-tap plug.
- viii. Install mechanical joint restraints and pipe joint restraints per Section 4.

(b) Disinfection of Domestic Water System

- i. Flush new system through blow off assembly.
- ii. Conduct clearwater/bacteriological testing per Section 11:
One test for each blow off assembly.
Provide District Engineer with a copy of the test results.
Flush and re-test when necessary.

(c) Bracing

- i. Bracing shall be by restraint systems per Section 5 and the District details.
- ii. Thrust blocks shall be installed at the plug per Section 5 and the District details.

9.4.7 Fire Hydrants

(a) Alignment

- i. Hydrant shall be set plumb with pumper nozzle facing roadway.
- ii. Center of pumper nozzle shall be 18-inches to 25-inches above finish grade unless otherwise specified.
- iii. Breakaway flange shall be a minimum of 3-inches and a maximum of 6-inches above finish grade unless otherwise specified.
- iv. Only one (1) extension barrel section is permitted to achieve the proper clearance.

(b) Bracing

- i. Bracing shall be by restraint systems per Section 5 and the District details.
- ii. Thrust blocks shall be installed at the hydrant shoe and main line tee per Section 5 and the District details.

(c) Drain

Provide drain pocket of no less than ½ cubic yard of granular material.
Extend granular material above hydrant drain.
Cover granular material with non-woven geotextile prior to backfilling.

(d) Connection to Main

- i. Each hydrant shall be connected to the main using a swivel tee with a 6" (six inch) gate valve and valve box.
- ii. The branch line shall be restrained and wrapped, and the hydrant shoe and main line tee shall be thrust blocked.

(e) All fire hydrant installations shall be in accordance with the District details.

10. PROTECTION OF WATER LINES NEAR SANITARY SEWER FACILITIES

10.1 Crossings

- 10.1.1 Water mains should cross above residential sewer services or sanitary sewer mains and shall be laid to provide a vertical separation of at least 18" (eighteen inches) between the bottom of the water main and the top of the sewer.
- 10.1.2 When a new water main crosses an existing sewer at a point lower than 18" (eighteen inches) above the sewer, the water main shall be encased in concrete for 10' (ten feet) on each side of the sewer per Section 7.
- 10.1.3 Stability of the water and sewer lines at a point of crossing is critical and care must be taken to ensure proper bedding and compaction of both water and sewer lines.

10.2 Manholes

- 10.2.1 No water pipe or main shall pass through or come into contact with any part of a sewer or sewer manhole.

11. DISINFECTION AND TESTING

11.1 Notification

Notify District Engineer a minimum of 24 hours in advance of testing. All testing shall be made in the presence of the Engineer.

11.2 Testing Sequence

- Disinfection / Chlorination
 - Hydrostatic Testing
 - Flush Line, Dechlorination of discharged water, Refill
 - Clearwater / Bacteriological Testing
 - Tracer Wire Continuity Testing
 - Corrosion Protection System Testing, if installed
- A District representative must be present for all testing.

11.3 Disinfection/Chlorination

11.3.1 Disinfection Chemicals

AWWA B300: Hypochlorite
AWWA B301: Liquid Chlorine
AWWA B303: Sodium Chlorite

11.3.2 Hypochlorite Tablet Adhesive

Certified to NSF Standard 61
Permatex RTV Clear or approved equal.

11.3.3 Procedure

- (a) All main extensions shall be chlorinated in accordance with AWWA C651.
- (b) The chlorination of the finished pipeline shall be done prior to the hydrostatic testing.
- (c) Before filling the pipe with water, the pipe shall be clean and free of debris to the satisfaction of the Engineer.
- (d) Chlorine tablets may be used for disinfection in 16-inch and smaller pipe. Tablets shall be attached to the inside top of the pipe with an acceptable, food grade approved, adhesive prior to the pipe installation in the trench.

**Table 11.1
NUMBER OF HYPOCHLORITE TABLETS OF 5-GRAM STRENGTH
REQUIRED FOR A DOSE OF 50 mg/l***

Pipe Length, ft	Pipe Diameter, in			
	6	8	12	16
13 or less	2	2	6	8
18	2	4	8	12
20	2	4	8	14

*Based on 3.25 gram available chlorine tablet

- (e) 20-inch and larger pipe requires chlorine slurry or liquid fed into the water being used in filling the pipe.
- (f) Chlorinated water shall be held in contact with the pipe for 24 hours.
- (g) Perform chlorination testing: Upon completion of the 24-hour retention period required for disinfection, the water in the pipeline shall be tested and have a residual chlorine content of not less than 50 mg/l.
- (h) Obtain one (1) test sample for every 1,000 linear feet of pipe.

11.4 Hydrostatic Testing

11.4.1 General

- (a) Conduct hydrostatic testing accordance with AWWA C600.
- (b) Hydrostatic testing shall be completed after chlorination testing and prior to the clearwater / bacteriological testing and final connection to the existing system.
- (c) Before applying test pressure, completely expel air from section of piping under test. Provide temporary blow-off(s) or use fire hydrant(s) as necessary so air can be expelled as pipeline is filled with water.
- (d) Test Pressure: 150 psi or 50 psi above the working pressure at the point of testing, whichever is greater.
- (e) Slowly bring piping to test pressure and allow system to stabilize. Do not open or close valves at differential pressures above rated pressure.
- (f) Conduct hydrostatic test for at least a 1-hour duration.
- (g) Examine exposed piping, fittings, valves, hydrants, and joints carefully during hydrostatic pressure test. Repair or replace damaged or defective pipe, fittings, valves, hydrants, or joints discovered, following pressure test.

11.4.2 Testing Allowance

- (a) Defined as the quantity of makeup water that must be supplied into the tested pipe or any valved section thereof to maintain pressure within 5 psi of the specified test pressure after the pipe has been filled with water, brought to test pressure and air expelled.

- (b) Shall not be measured by a drop in pressure in a test section over a period of time.
- (c) No pipe installation will be accepted if the amount of makeup water is greater than that determined by the following formula:

<u>Ductile Iron Pipe</u>	<u>PVC Pipe</u>
$L = \frac{SD (P)^{1/2}}{133,200}$	$L = \frac{SD (P)^{1/2}}{148,000}$

- L = testing allowance, in gallons per hour
- S = length of pipe tested, in feet
- D = nominal diameter of pipe, in inches
- P = average test pressure during leakage test, in psi

Refer to Table 11.2 at the end of this section.

- (d) When leakage exceeds specified acceptable rate, locate source and make necessary repairs. Repeat test until specified leakage requirements are met.

11.5 Clearwater/Bacteriological Testing

- 11.5.1 Upon completion of passing chlorination and hydrostatic tests, the pipeline shall be thoroughly flushed.
- 11.5.2 Dispose of heavily chlorinated water. The environment to which the chlorinated water is to be discharged shall be inspected. If there is any possibility that the chlorinated discharge will cause damage to the environment, a neutralizing chemical shall be applied to the water to be disposed (refer to Appendix C of AWWA C651).
- 11.5.3 Refill water line. Before the new water main is finally connected to the distribution system for use, conduct clearwater / bacteriological testing.
- 11.5.4 Conduct clearwater / bacteriological testing in accordance with AWWA C651.
- 11.5.5 Samples for clearwater / bacteriological testing shall be tested for residual chlorine and bacteriological quality.
 - (a) Residual Chlorine shall not exceed 0.5 mg/l.
 - (b) Bacteriological test shall show absence of coliform organisms.

11.6 Tracer Wire Continuity Test

- 11.6.1 A continuity test shall be performed on the installed tracer wire at the Contractor's expense. A District representative must be present.
- 11.6.2 The Contractor shall repair/replace sections of tracer wire that do not transmit proper signals during the test.

11.7 Test Results

11.7.1 Chlorination Testing Report

- (a) Type and form of disinfectant used
- (b) Date and times of disinfectant injection
- (c) Test locations
- (d) Name of person collecting samples
- (e) Initial and 24 hour disinfectant residuals in treated water in mg/l for each outlet tested
- (f) Date and times of flushing
- (g) Disinfectant residual after flushing in mg/l for each outlet tested

11.7.2 Hydrostatic Testing Report

- (a) Specific length of pipe tested
- (b) Test Pressure
- (c) Duration of the test
- (d) Amount of make up water
- (e) Engineer and the Contractor shall sign report

11.7.3 Clearwater / Bacteriological Testing Report

- (a) Date issued, project name, and testing laboratory name, address, and telephone number.
- (b) Time and date of water sample collection.
- (c) Name of person collecting samples.
- (d) Test locations.
- (e) Initial and 24 hour disinfectant residuals in mg/l for each outlet tested.
- (f) Coliform bacteria test results for each outlet tested.
- (g) Certify water conforms, or fails to conform, to absence of coliform bacteria.

Table 11.2 – Hydrostatic Testing Allowances

DUCTILE IRON PIPE										
Hydrostatic testing allowance per 1,000 ft of pipeline* - <i>gph</i> per AWWA C600										
Avg. Test Pressure - <i>psi</i>	Nominal Pipe Diameter – <i>in.</i>									
	4	6	8	10	12	16	20	24	30	36
250	0.47	0.71	0.95	1.19	1.42	1.90	2.37	2.85	3.56	4.27
225	0.45	0.68	0.90	1.13	1.35	1.80	2.25	2.70	3.38	4.05
200	0.43	0.64	0.85	1.06	1.28	1.70	2.12	2.55	3.19	3.82
175	0.40	0.59	0.80	0.99	1.19	1.59	1.98	2.38	2.98	3.58
150	0.37	0.55	0.74	0.92	1.10	1.47	1.84	2.21	2.76	3.31

PVC PIPE										
Hydrostatic testing allowance per 1,000 ft of pipeline* - <i>gph</i> per AWWA Manual M23										
Avg. Test Pressure - <i>psi</i>	Nominal Pipe Diameter – <i>in.</i>									
	4	6	8	10	12	16	20	24	30	36
250	0.43	0.64	0.85	1.07	1.28	1.71	2.14	2.57	3.21	3.85
225	0.41	0.61	0.81	1.01	1.21	1.62	2.02	2.42	3.03	3.64
200	0.38	0.57	0.76	0.96	1.15	1.54	1.92	2.30	2.88	3.46
175	0.36	0.53	0.71	0.89	1.07	1.42	1.78	2.14	2.67	3.20
150	0.33	0.50	0.66	0.83	0.99	1.33	1.66	1.99	2.49	2.99

* If the pipeline under test contains sections of various diameters, the testing allowance will be the sum of the testing allowance for each size.

Supplement to Section 11

Sample Hydrostatic Testing Report for Water Mains

HYDROSTATIC TEST - WATER

Date: _____
Passed: _____ Failed: _____
Daily Report No.: _____
Page: _____

Client/Owner: _____ Job No: _____
 Project Name: _____
 Contractor: _____
 Location: _____
 Test No.: _____ Time Begin: _____ Time End: _____
 Weather: _____ (Temperature) _____ (Condition)

FOOTAGE:						
4"	6"	8"	12"	16"	24"	TOTAL
ALLOWABLE LEAKAGE:						
4"	6"	8"	12"	16"	24"	TOTAL
METER READING:						
Begin	Filled	½ Hour	1 Hour	1 ½ Hour	2 Hours	
P.S.I.						
Standard Pressure	Begin	½ Hour	1 Hour	1 ½ Hour	2 Hours	

ALLOWABLE LEAKAGE PER 1000' OF PIPE	
Pipe Size	Gallons Per Hour
4"	0.37
6"	0.55
8"	0.74
12"	1.10

THE FOLLOWING PEOPLE ATTENDED
District Engineer: _____
District: _____
Contractor: _____
Others: _____

Remarks: _____

_____ % of Project Tested _____ % of Project Completed

FIELD ADMINISTRATOR: _____ CONTRACTOR: _____

DISTRICT REP: _____

PROCEDURES

12. CONSTRUCTION PLAN REVIEW AND APPROVAL

The following procedures have been developed by the Castle Pines North Metropolitan District in order to coordinate and unify the submittal, review, and approval of construction plans and specifications.

12.1 General

- 12.1.1 All plans shall be in compliance with the Engineering Standards and Specifications of the Castle Pines North Metropolitan District.
- 12.1.2 The owner/developer is responsible for payment to CPNMD of all fees and charges associated with the plan review process including the charges of the District Engineer.
- 12.1.3 No construction may take place until the easements are fully-executed and recorded.
- 12.1.4 No construction may take place until the plans have been approved and a preconstruction meeting has been held.
- 12.1.5 Plans and specifications are approved for a one-year period. If construction has not begun within this one-year period, or if it has been halted and not re-started prior to expiration of the approval period, the plans must be resubmitted for review and approval.

12.2 Submittal and Review Procedures

12.2.1 Pre-Design Conference

- (a) The owner, developer, or design engineer may request a pre-design conference by contacting the District Manager. This conference is not required, but will be held upon the request of the owner, developer or design engineer.

12.2.2 Submittals

- (a) Two (2) copies of preliminary water plans, along with AutoCAD files saved in version 2011 or older, shall be submitted to the District Manager. The plans will be reviewed by the District Engineer for compliance with the District's standards and specifications as well as for compliance with the District's integrated water system. The approval of plans will also be subject to the ability of the District to operate and maintain the proposed facilities in an efficient, economical manner.
- (b) Four (4) original sets of the District's "Application for Main Line Extension" shall be submitted to the District Manager prior to plan review completion.
- (c) All easement information, in accordance with these Specifications, shall be submitted to the District Manager or Engineer as part of the plan review.
- (d) The Design Engineer shall submit system hydraulic sizing calculations upon request.

- 12.2.3 Upon completion of the District's review of preliminary plans, one copy of the plans will be returned to the design engineer for required revisions. A conference may be scheduled by the District Manager and District Engineer to discuss the needed revisions if it is deemed necessary or if it is requested by the design engineer.
- 12.2.4 When all revisions have been completed by the engineer, two (2) copies of the revised plans and AutoCAD files saved in version 2011 or older shall be submitted to the District Engineer, who will complete a second review. The initial redlined drawings must be returned to the District Engineer with the second submittal.
- 12.2.5 If further revisions are required, one copy of the plans, redlined to indicate needed revisions, shall be returned to the design engineer. Two (2) copies of the revised plans and AutoCAD files shall be submitted to the District Manager.
- 12.2.6 When the plans are ultimately approved, ten (10) copies of the plans, stamped and signed by a professional engineer in Colorado, and AutoCAD files saved in version 2011 or older, shall be submitted to the District Engineer.
- 12.2.7 The approved plans will be released by the District Engineer at the preconstruction meeting. NO construction may take place until a preconstruction meeting has been held.

13. CONVEYANCE AND ACCEPTANCE PROCEDURE

- 13.1 Upon receipt of plans for review and approval, the Engineer shall send four (4) copies of the Conveyance and Acceptance application to the Developer for execution. Four (4) original copies are required. The District Engineer will hold all four (4) copies of the form completed by the Developer.
- 13.2 Upon completion of the plan review and receipt of the four (4) original Conveyance and Acceptance applications, the plans will be approved.
- 13.3 Prior to the expiration of the probationary period (refer to Section 15.7), the utility lines shall be inspected for final acceptance and maintenance by the District Engineer and Manager. The Developer and his Contractor shall correct any deficiencies observed during the final inspection, within the time period set by the District personnel or the District Engineer.
- 13.4 Upon final acceptance, the District Manager will distribute executed Conveyance and Acceptance forms. Copies will be distributed as follows:
- | | |
|-------------------|----------|
| Developer | - 1 Copy |
| District Engineer | - 1 Copy |
| District Manager | - 1 Copy |
| District Attorney | - 1 Copy |

14. WATER EASEMENTS

Easements are required wherever a water main is not in a public right-of-way. All easements shall be prepared according to the following specifications:

- 14.1 In areas where water mains are installed in easements, the water mains shall be located within the easements as shown on the construction plans.
- 14.2 If a water main is to be located in an easement, such as between lots, a valve shall be located at each property line.
- 14.3 Exclusive water main easements must be a minimum of thirty feet (30') in width.
- 14.4 Planned unit developments (PUDs), real estate developments consisting of separate buildings in a common ownership and/or management, which buildings are not separated by dedicated public streets within the exterior boundaries of the planned unit development, shall have easements with a minimum width of thirty feet (30') of which the District shall have exclusive use of twenty feet (20') thereof, except for right angle utility crossings. The easement must have a paved surface and the boundaries must be delineated by curb and gutter or an approved, permanent surface.
- 14.5 Non exclusive easements must be a minimum of fifty feet (50') in width.
- 14.6 No water main shall be located less than ten feet (10') from the edge of an easement.
- 14.7 All easements granted to the Castle Pines North Metropolitan District shall be prepared according to procedures outlined in the "Easement Preparation and Submittal Procedures and Checklist" located at the end of this Section.
- 14.8 Plans for water main construction within easements shall not be authorized for construction prior to the acceptance of the easements by the Castle Pines North Metropolitan District, nor prior to the easements being fully executed and recorded.
- 14.9 All required marker posts within the easements must be installed prior to acceptance of water mains. Valves, vaults and horizontal bends shall be marked using a steel marker post per the District detail.

Water Easement Preparation and Submittal Procedures and Checklist Castle Pines North Metropolitan District

These procedures have been prepared in order to provide general guidelines for the submittal of information necessary for the preparation of water and sewer easements within the Castle Pines North Metropolitan District. This information generally includes legal descriptions and drawings, an overall easement drawing, and a Title Commitment. Information contained herein should be used in conjunction with the District's water and sewer specifications.

All information required in the submittal section of these procedures must be presented to the District prior to the approval and release of construction plans. Submittals must be accompanied by this form, with Part A completed by the easement Grantor or his designated representative.

Submittals

The following information shall be submitted to the District Manager in three (3) copies:

1. The Castle Pines North Metropolitan District easement preparation checklist with the appropriate sections completed by the easement Grantor or his designated representative.
2. Copy of the preliminary/final plat for the project.
3. A legal description of each easement. A separate legal description is required for each separate ownership.
4. A drawing of each easement on an 8 ½-inch by 11-inch sheet showing distances and bearings, north arrow, ties to recognized land corners, and the acreage and square footage of the proposed easement. The drawings shall be prepared according to District Standards. A separate drawing is required for each legal description.
5. A title commitment or title policy on the entire tract of land to be developed. The document must be current.
6. A boundary survey of the tract of land to be developed showing the location of the proposed easement(s) as well as the location of all structures, ditches, existing easements and other encumbrances explained in the title commitment.
7. A title commitment on all offsite easements specific to the easement legal description.
8. A boundary survey of the off-site easements indicating the relationship of off-site easements to the proposed development. Encroachments and/or encumbrances on the proposed off-site easements, such as existing easements, ditches, and structures, must be indicated on the drawing.

Checklist

PART A (to be completed by Grantor or his Engineer)

1. Please type or print the name of the Grantor for each easement exactly as the Grantor's name appears on the Deed by which the Grantor took title to the property. If the Grantor is a corporation, please list the state of organization and the names of all general partners.

<u>Easement No.</u>	<u>Name, Title, Address, and Telephone Number of Grantor(s)</u>
_____	_____

_____	_____

_____	_____

_____	_____

_____	_____

2. Please list and describe special provisions that should be included in the easement documents. Include such things as existing storm sewer, irrigation systems, etc. located within the proposed easement boundaries. License Agreements may be necessary for these encroachments.

<u>Easement No.</u>	<u>Special Provisions</u>
_____	_____

_____	_____

_____	_____

_____	_____

_____	_____

PART B (to be completed by the District Engineer)

1. Please provide the following information:

<u>Easement No.</u>	<u>Grantor</u>	<u>Width & Type of Easement (30' Excl., 50' Non-excl., 30' PUD)</u>
_____	_____	_____
_____	_____	_____
_____	_____	_____
_____	_____	_____
_____	_____	_____

2. The easement legal descriptions, drawings, and proposed locations of utilities have been compared and reviewed, and are recommended for acceptance.

District Engineer

Date

PART C (to be completed by the District Manager)

1. Please state any special considerations or time restraints which should be brought to the attention of the District's Attorney. Include a brief background statement describing location and extend of development as well as proposed points of connection to existing mains.

2. I have reviewed the proposed easements and recommend that they be accepted by the District.

District Manager

Date

PART D (to be completed by the District's Attorney)

1. Please provide the following information:

<u>Easement No.</u>	<u>Date Recorded</u>	<u>County</u>	<u>Reception No.</u>
_____	_____	_____	_____
_____	_____	_____	_____
_____	_____	_____	_____
_____	_____	_____	_____
_____	_____	_____	_____

2. Copies of all easements have been forwarded to:

- _____ Grantor(s)
- _____ District Manager (with copy of checklist)
- _____ District Engineer (with copy of checklist)

15. PRECONSTRUCTION AND CONSTRUCTION PROCEDURES

15.1 Preconstruction Meeting

The Contractor shall be responsible for arranging a preconstruction meeting prior to the start of any construction. The District Manager, District Engineer, Contractor, Owner, Owner's Engineer, surveyor, soils consultant, County and/or City representatives must be represented at this meeting.

The Contractor shall be responsible for notifying the District Engineer and District Manager at least 48 hours prior to the start of any construction. If work is suspended for any period of time after initial start-up, the Contractor must notify the District Engineer 24 hours prior to start.

15.2 Construction Water

15.2.1 The Developer/Contractor is responsible for obtaining the necessary permits and paying the necessary fees to the District for construction water. Contact the District at 303-688-8550 to obtain a meter for the project and pay the required fees.

15.2.2 Fees include:

- One-time, refundable deposit to obtain a meter
- Monthly charge for use of meter
- Consumption charges based on gallons used from meter readings.

15.2.3 All water to be used in backfill and compaction, site cleanup, dust control measures, flushing sewer lines, etc., shall be obtained from a fire hydrant specified by the District. All water shall be obtained through the District's meter.

15.2.4 Water used to fill and flush new water systems may be obtained at no cost from the water main tie-in allowed for testing.

15.2.5 All water used to flush sewer and water mains shall be disposed of properly by the Contractor per local and/or State laws and regulations. The Contractor is responsible for obtaining all necessary discharge permits from the appropriate governing agencies.

15.2.6 Contractors completing work on behalf of the District will not be required to pay the monthly meter fee. However, payment of the meter deposit and consumption charges will be required.

15.3 Locating Existing Lines

15.3.1 At all points of connection of new water mains to existing mains, the Contractor will be responsible for excavating and verifying the location of existing lines, prior to the installation of any new construction. If it is necessary to shut down any portions of the existing water system to make such connection, the Contractor will be responsible for notifying, in writing, all District customers to be affected by the water outage at least 24 hours prior to such outage. The duration of water outage to the existing District customers

shall be minimized and, if directed by the District Engineer, the Contractor shall provide temporary water supply to customers by means of tank trucks, temporary connections to charged facilities, etc.

All existing water valves shall be operated only by a representative of the District. The Contractor shall not be allowed to operate any existing valve.

15.4 Pipeline Backfill

- 15.4.1 No pipe or appurtenance shall be backfilled, nor covered with bedding material, above the spring line of the pipe prior to the review by the District. Arrangements shall be made by the Contractor to assure that all construction is reviewed by the District Engineer prior to backfilling. Any pipe covered prior to review and acceptance shall be excavated by the Contractor to allow for review. This shall be done at no expense to the District.

15.5 Record Drawings

- 15.5.1 The Contractor is responsible for maintaining as-built drawings to include all distances between fittings, locations of valves, blow-offs, services, etc. The Contractor shall record all deviations from the construction drawings.
- 15.5.2 As-built drawings produced using AutoCAD must be submitted to the District Engineer for review before probationary acceptance.
- 15.5.3 The as-builts should be 12-inches by 18-inches. Required sets include one (1) copy of black line prints and two (2) copies of reproducible mylar prints.
- 15.5.4 Two (2) copies of the AutoCAD files (with as-built information), saved in version 2011 or older, must be submitted to the District Engineer.

15.6 Construction Observation

15.6.1 General

- (a) The District and/or District Engineer shall decide any and all questions that may arise as to the quality and acceptability of the materials furnished and the work performed. The District and/or District Engineer shall decide all questions which may arise as to the interpretation of the District Standards and Specifications. The District Engineer, acting as the District's representative, is not a guarantor of the construction Contractor's obligations and performance of the Contract.
- (b) Observation of work in progress and on-site visits are not to be construed as a guarantee by the District Engineer and the District of the Contractor's contractual commitment.
- (c) The District Engineer and the District are not responsible for safety in, on, or about the project site, nor compliance by the appropriate party of any regulations relating thereto.
- (d) The District Engineer and the District, exercise no control of the safety or adequacy of any equipment, building components, scaffolding, forms, or other

work aids used in or about the project and do not supervise the Contractor or his forces.

15.6.2 Overtime

- (a) Any construction observation performed at times other than between the hours of 7:30 AM and 5:00 PM, Monday through Friday or on holidays that may fall on a weekday shall be done at the Contractor's expense. The cost will be based on the current billing rate for a Field Administrator. The minimum charge for weekend (Saturday or Sunday) or holiday observation shall be four (4) hours per day. The District Engineer shall determine whether or not overtime construction observation is necessary.

15.7 Construction Probationary Period

- 15.7.1 All Construction, including labor, materials and settlement of backfill, shall be guaranteed by the Owner/Developer for a period of two (2) years from the date of acceptance of construction by the District Manager and District Engineer. During the probation period, the expense of any repairs or maintenance to the lines, appurtenances, and facilities shall be the responsibility of the Owner/Developer. The District reserves the right to insure proper operation of its system and to perform any cleaning, repairs or other maintenance during the probationary period at the expense of the Owner/Developer.
- 15.7.2 The Owner/Developer shall be responsible for the proper alignment and cleanliness of all valve boxes and manholes during the probationary period or until the street paving has been completed, whichever is longer. Written notification of any deficiencies discovered during this period will be provided by the District Manager or District Engineer. If the deficiencies are not corrected within the prescribed time limits, the corrections shall be completed by the District at the complete expense of the Owner/Developer.

16. ACCEPTANCE AND RELEASE FOR TAPS

A main shall be accepted by the District and released for taps when the following conditions have been met:

- 16.1 All tap fees have been paid to the District.
- 16.2 The main and all appurtenances have been installed to the satisfaction of the District Engineer.
- 16.3 All pertinent notes and measurements have been made by the Contractor on the record drawings. One (1) set of half-size black line prints with two (2) sets of half size reproducible mylar prints of the record drawings have been submitted to, and approved by, the District Engineer. The AutoCAD files saved in version 2011 or older have been submitted to the District Engineer.
- 16.4 The main has been successfully pressure tested to the requirements of Section 11. Pressure testing is mandatory.
- 16.5 The main has passed high chlorine and bacteria testing by a certified laboratory. The results have been forwarded to the District Engineer.
- 16.6 All compaction test results required by the Engineer have been submitted.
- 16.7 All easements have been submitted and recorded with the appropriate County.

17. WATER LINE TAPPING PROCEDURES

17.1 General

- 17.1.1 No connection to a Castle Pines North Metropolitan District owned water main will be allowed prior to the purchase of a District tap permit, or "Connection Permit."

Tap permits will not be issued prior to District acceptance of the water main to be tapped and payment of all fees.

- 17.1.2 Water service line installations shall be in accordance with AWWA C-800, and in accordance with the standards and specifications of the Castle Pines North Metropolitan District.

- 17.1.3 All taps shall be made by a contractor approved by the District.

- 17.1.4 The property owner must provide a property line shut-off valve for each domestic service that is easily accessible to District personnel. Shut-off valves may be installed inside the building only with prior approval by the District. Where the shut-off valve is installed inside the building, the valve must be a locking-type valve approved by the District, and the property owner must provide District personnel with complete access to the valve at all times.

- 17.1.5 All taps, service lines, fittings, and meter settings (including internal settings) must be inspected by the Castle Pines North Metropolitan District. It is the developer's responsibility to contact the District at (303) 688-8550.

- 17.1.6 Call (303) 688-8550 to schedule an on site pre-construction meeting for all meter settings 1-1/2 inch or larger.

- 17.1.7 Individual service line PRVs are required (when area pressure exceeds 80 psi).

17.2 Service Sizing

- 17.2.1 Refer to section 3.2 of these specifications.

17.3 Location

- 17.3.1 Water services shall be located a minimum of ten feet (10') from sewer services, and will be generally located on the uphill side of the sewer services.

- 17.3.2 Service taps shall be located 2-feet minimum from the closest pipe joint and 3-foot minimum from the next closest service tap (maximum of 4 taps per length of pipe).

- 17.3.3 Service lines shall be installed in a continuous straight line perpendicular to the main and shall enter the property a minimum distance of five feet (5') from the nearest lot corner.

- 17.3.4 The main to be tapped must extend a minimum distance of eight feet (8') along the front lot line of the property to be served.
- 17.3.5 For lots at the end of cul-de-sac streets, the main to be tapped must not be more than fifty feet (50') from the property line of the premises to be served. The service pipe between the main and the property line shall be in a continuous straight line and shall enter the property a minimum distance of five feet (5') from the nearest lot corner.
- 17.3.6 **Meters for domestic and commercial services shall be located inside the building per District details 30A-W and 31W. Meters for separate irrigation services and certain multi-family services shall be located in concrete pits or vaults per District details 30B-W and 32W. Meter locations shall be approved by the Castle Pines North Metropolitan District. It is the developer's responsibility to contact the District at (303) 688-8550.**
- 17.3.7 All water service lines shall have a "V" cut or chiseled in the curb where concrete curb and gutter is present.

17.4 Depth

- 17.4.1 All water service pipes shall be installed a minimum of five feet (5') below the ground surface.
- 17.4.2 If the grade of the ground surface is lowered subsequent to installation of the service pipe, the property owner shall be responsible for lowering the pipe to provide a minimum of five feet (5') of cover over the pipe.

17.5 Materials

- 17.5.1 All service lines consist of corporation stops, curb stops, meters, and service pipelines. Meter pits or vaults shall be used for separate irrigation services and multi-family services with prior approval by the District.
- 17.5.2 The connection shall be made using a corporation stop of the same size as the service line through a bronze tapping saddle. Corporation stops shall be AWWA Standard taper threads by copper flare, Ford or Muller. Tapping saddles shall be double bronze strapped for use with ductile iron pipe. Outlet threads shall be AWWA Standard taper threads.
- 17.5.3 Insulators: Domestic service lines of dissimilar metals shall be electrically insulated by means of District-approved insulating fittings or gaskets. Care shall be taken to properly install corporation stops and provide enough slack in the service lines to protect against pullout.
- 17.5.4 Service lines three inches (3") and smaller shall be type K (soft) copper. All connections shall be "flared".
- 17.5.5 Curb stops (property line shut off valves) shall be Muller 15000 or Ford B-22-444 with Box-Tyler 4-1/4" drop lid #6870.

- 17.5.6 Building water service backflow preventer shall be Febco 805Y-BV double check assembly. Floor drain required.
- 17.5.7 Fire protection sprinkler system backflow preventer shall be Febco 825Y-BV reduced pressure principle assembly. A double check assembly may be used with prior approval by the District and South Metro Fire Protection District for low-risk applications. Floor drain required.
- 17.5.8 Shut off valves inside building to be globe-type valves.
- 17.5.9 District to supply water meter and remote read for installation by the Contractor. Remote read shall be located at the front garage door or at a location approved by the District.
- 17.5.10 The use of meter settings with bypass lines must be approved by the District prior to installation. If a bypass line is permitted, it must be a locking-type bypass approved by the District.
- 17.5.11 Irrigation system pressure vacuum breaker shall be Febco 765-BV. Floor drain required.
- 17.5.12 Meter pits shall be precast concrete and shall have cast iron cap-type lids with frost protection and a 2-inch opening for the meter transponder. Refer to District detail 30B-W.
- 17.5.13 Meter vaults shall be pre-cast concrete per Section 5 and per District detail 32W with a standard, 24-inch ring and cover per District detail 23W. PVC conduit shall be installed from the vault to a nearby building or post, and the meter transponder shall be mounted at a location approved by the District. Refer to District detail 33W.

17.6 Meter Pits or Vaults

- 17.6.1 Meter pits or vaults shall be frost proof and shall be located not more than five feet (5') inside the front or side property of each lot and not in an area such as a walk or driveway which may be subject to having portions of the pit or its cone covered with concrete or asphalt.
- 17.6.2 The pit/vault and cover must be located within a landscaped area. The pit or vault must be protected from the hazards that may surround it and must not be in an area which will be enclosed by a fence or have shrubs or other plantings overhanging the pit or otherwise interfere with the pit being readily accessible to meter readers or maintenance personnel. The pit or vault shall not be located in traffic areas.
- 17.6.3 Meter Pits: The lower portion of the meter pit shall consist of precast concrete rings twenty-four inches (24") in diameter. The concrete rings shall have a two-inch (2") wall thickness. The upper portion shall be standard meter pit dome, made of cast iron, having a twenty-four inch (24") base with an inner frost lid and an outer pit cover cap-type lid made of cast iron, which has a screw-type latching device controlled by a five (5) sided nut. The lid shall have a 7" diameter recess and 2" diameter hole for installation of the meter transponder. The frost lid must have one edge slotted for the required wiring

for remote-read equipment. The meter pit dome is to be installed in such a manner that the base aligns with and rests firmly on the lower concrete rings. The chimney portion of the meter pit dome shall extend a full three inches (3") above the finished grade of the ground in the vicinity of the meter pit. (This will permit homeowners to install two inch (2") thick sod and have the meter pit cover be one inch (1") above the grass height.) See District detail 30B-W.

- 17.6.4 Meter Vaults: The design of meter vaults shall be submitted to the District's Engineer for review. The interior of the vault shall be large enough to permit adequate work space for meter disassembly and replacement by maintenance personnel. Additionally, vaults will have plastic manhole steps built into their sidewalls to permit proper access by maintenance personnel. Refer to Section 5 and detail 32W for vault specifications. PVC conduit shall be installed from the vault to a nearby building or post, and the meter transponder shall be mounted at a location approved by the District. Refer to detail 33W.
- 17.6.5 Meters will not be installed in pits or vaults until such time as District maintenance personnel have inspected the pit or vault to ascertain that the installation of the pit or vault is proper and will facilitate proper meter reading and maintenance.

17.7 Meters

- 17.7.1 All meters must be obtained from the District office at 7404 Yorkshire Drive, Castle Pines, CO 80108. Refer to Section 17.5 for more information.
- 17.7.2 The Contractor must notify the District at 303-688-8550 one full working day in advance of when they expect to be making a meter setting and arrange for District maintenance personnel to be on site for installation of the meter. Prior to placing meters into operation after installation, District maintenance personnel will verify that direct and remote readings on the same installation are identical.

17.8 Fire Lines

- 17.8.1 All plans pertaining to the installation of fire lines must be reviewed by South Metro Fire Protection District and Castle Pines North Metropolitan District and must comply with the requirements of all both agencies.
- 17.8.2 No fire line installation will be smaller than four inches (4") diameter.
- 17.8.3 The fire line shall be ductile iron, class 52, fully restrained per the specifications in Section 5.
- 17.8.4 No horizontal or vertical bends are allowed from the District main to the building.
- 17.8.5 A tap permit (Connection Permit) from the District and approval by South Metro Fire Protection District shall be obtained prior to the installation of any fire line.
- 17.8.6 The installed fire line must be reviewed and accepted by South Metro Fire Protection District and Castle Pines North Metropolitan District prior to backfill.

17.9 Backflow Prevention

A backflow prevention device approved by Castle Pines North Metropolitan District is required on the treated water service line for:

- All domestic single-family taps.
- All commercial and multi-family domestic taps.
- Taps where there is a dual water supply on the premises.
- Fire lines.
- Irrigation lines.

Refer to Section 17.5 for more information.

17.10 Stop and Waste Valves – Irrigation Services

A stop-and-waste valve with box is required on all separate irrigation services between the meter pit or vault and the backflow preventer. Contractor shall install a drain under the valve, which shall consist of at least ¼ cu. yd. of 1.5-inch crushed rock or equal. Mirafi fabric or 8 mils poly shall be placed over the rock before backfill to prevent soil from filling the rock voids. The valve shall not be placed closer than 5-ft to the outside of the pit or vault per District standards. The valve shall be used as an aide to “winterize” the irrigation service.

17.11 Ownership

- 17.11.1 Services – The portion of the service pipe from the connection at the District's water supply main to the property line shall be owned by the Castle Pines North Metropolitan District. The portion of the service from the property line to the unit or building shall be owned by the property owner, with the exception of the water meter.
- 17.11.2 Fire lines – The portion of the fire line from the connection at the District's water supply main to the property line shall be owned by the Castle Pines North Metropolitan District. The portion of the fire line from the property line to the building shall be owned by the property owner.

17.12 Frozen Service Pipes

The District shall not be responsible for thawing frozen service pipes or appurtenances.

17.13 Repair

- 17.13.1 The District shall provide leak repair services ONLY to a portion of the service pipe as indicated below:
- (a) The District shall repair leaks originating on the segment of the water service pipe between the water main and the outlet side of the property line curb stop valve.

- (b) Where no curb stop valve exists, and there is an outside meter setting, the District will repair leaks originating on the segment of the service pipe between the water main and the outlet side of the water meter.
 - (c) Where no curb stop valve exists, and no outside meter setting exists, the District will repair leaks originating on the service pipe between the water main and the customer's property line.
 - (d) Fire Lines – The District will repair leaks originating on the segment of fire line between the water supply main and the outlet side of the fire line property line valve. Further, leaks on service pipes connected to fire lines shall be repaired by the District in accordance with the guidelines set forth in (a) through (c) above.
- 17.13.2 The District shall repair leaks on the above referenced segments of service pipes only when the District has determined that a leak is on the District-owned portion of pipe.
- 17.13.3 The District shall not be responsible for repairs completed prior to notification of the District, nor for repairs completed by other than under District direction. No reimbursement for leak repairs carried out under the above-described circumstances will be granted by the District.
- 17.13.4 The customer/property owner shall retain complete responsibility for the maintenance and repair of all segments of the water service pipe and its appurtenances not listed in (a) through (d) above. Leaks originating on the customer-maintained portion of the service line shall be repaired, without delay, at the customer's expense. Failure to repair leaks within the time prescribed by the District shall result in termination of service until repairs are completed. All repairs shall be made in accordance with the District's Engineering Standards and Specifications and in accordance with the District's Rules and Regulations.

17.14 Stub-ins

- 17.14.1 When a stub-in connection is installed to permit street paving or in advance of future development, it shall be located to provide a future connection that is in accordance with applicable standards at the time of activation. There is no assurance that any stub-in will meet the requirements for conversion to a service line at the time of activation. A licensee that installs a stub-in does so with the understanding that it shall be the responsibility of the licensee to modify, reconstruct, relocate, replace, or remove the stub-in, as necessary, prior to converting it to a service line to meet current Standards. Stub-ins and converted service lines may not be located in a manner wherein the stop box and meter setting are beneath a driveway, sidewalk, street, parking area, or within specified limits of side lot lines and permanent obstructions. Any stub-in that is not activated within two (2) years will be cut off at the main at the expense of the licensee. Water may not be taken from a stub-in for any purpose.
- 17.14.2 The stub-in shall be installed to the property line curb stop valve. The valve and valve box shall be installed, and the valve shall be left in the closed position.

17.15 Abandonment or Removal of Service Lines

- 17.15.1 It may become necessary to remove or abandon a service line or stub-in due to inactivity, redevelopment, and changes in water requirements for the premises or to relocate a service due to changes in the configuration of the premises. An abandoned or relocated service line shall have the tap cut at the main or fireline to ensure that it cannot be used to remove water from the system. Service line tap cuts shall be witnessed by the District. Tap cuts shall be coordinated through the District at 303-688-8550. Taps that are 3-inches and larger shall require water plans for review. Service lines must be metered until disconnected from the main in the presence of District personnel.
- (a) **Services, 2-Inch and Smaller:** The service connection shall be excavated where the corporation stop is inserted into the water main. The corporation stop shall be closed, the service tubing or piping shall be removed from the corporation stop, and a section of the water service line at least 12 inches long shall be cut out. A cap shall be placed on the threaded outlet of the corporation stop to prevent leakage. The curb or valve box over the curb stop shall be removed in its entirety or cut off at least 18 inches below the ground line. The meter shall be delivered to the District office for a final test and reading. The meter may not be used again in the District's system. The meter pit, if present, may be removed in its entirety. If it is left in place, it shall be cut off at least 18 inches below the ground line and filled with sand or other fill material.
- (b) **Services, 3-Inch and Larger:** The service connection shall be excavated over the service tee on the water main. The valve at the main shall be removed and the connecting fitting (tee or tap) plugged. The property line valve box shall be removed or cut off at least 18 inches below the ground line. The meter shall be delivered to the District office for a final test and reading. The meter may not be used again in the District's system. The meter vault, if present, may be removed in its entirety. If it is left in place, it shall be cut off at least 18 inches below the ground line and filled with sand or other fill material.

NOTES AND DETAILS

18. CPNMD GENERAL WATER NOTES

The following notes shall be included on all water system improvement plans:

1. All water lines and system plans and construction, shall conform to the Castle Pines North Metropolitan District Standards and Specifications and be subject to construction observation by the District representatives. Copies of the District Standards and Specifications may be obtained from the District Manager. The Owner, his engineer or contractor, shall schedule a preconstruction meeting with the District Manager and District Engineer at least 48 hours prior to the start of construction. Plans with the District Review Stamp will be distributed at the preconstruction meeting. No construction will be permitted until formal completion of easements and recording, and prior to the preconstruction meeting.
2. The pipe specified by the Owner or his engineer for the water lines in this project is [Class 50, Ductile Iron Pipe (DIP)] OR [AWWA C900 DR18 PVC]. All water lines shall have a minimum of five feet (5') of cover and be located a minimum of ten feet (10') from the sanitary sewer, and three feet (3') from the edge of concrete curb and gutter pan. All valves and fittings are to be polywrapped.
3. Probationary acceptance of the new water lines is contingent upon receiving copies of:
 - Water line trench compaction test results,
 - Record drawings, and
 - Health Department tests. (Chlorine and/or clear water as required).
4. Theoretical static water pressures are estimated to range from _____ psi at USGS Elevation _____ to _____ psi at USGS Elevation _____ based upon a hydraulic gradient of USGS Elevation _____. The District has provided only the hydraulic gradient elevation. This hydraulic gradient, which was provided at the time of plan review, may change in the future as overall water system operations warrant. The District requires PRVs on all individual services where the static water pressure is greater than 80 psi.
5. All water line valves shall be set at the intersection of the extended property line and water line except where that point falls in the flow line of a concrete cross pan. In that case, the valve shall be located so that surface drainage does not infiltrate the valve box. Valve boxes shall be set at an elevation in accordance with City/County paving requirements.
6. Polyethylene wrapping shall be installed around all ductile iron pipe, fittings, valves, fire hydrant barrels, and rods and clamps. The polyethylene shall have a minimum thickness of eight (8) mils.
7. All water lines shall be chlorinated in accordance with A.W.W.A. C-651, "Disinfecting Water Mains". The preferred method is to use sufficient chlorine tablets to produce a 50 mg/l solution. The tablets shall be adhered to the top of the pipe with Permatex Clear RTV. The chlorination of the water line shall be performed prior to the hydrostatic testing.
8. All water lines shall be hydrostatic tested in accordance with A.W.W.A. C600 Section 5, "Hydrostatic Testing". All water lines shall be tested to a minimum of 150 psi or 50 psi above working pressure, whichever is greater. The test shall be scheduled by the

District and coordinated with any other reviewing or approving agency. The allowable leakage rates are as follows:

Pipe Size (Inches)	Allowable Leakage (Per 1000 Feet of Pipe, Gallons Per Hour)	
	<u>DI</u>	<u>PVC</u>
4	.37	.33
6	.55	.50
8	.74	.66
12	1.10	1.00
16	1.47	N/A
20	1.84	N/A

9. Existing valves in the District may only be operated by District personnel.
10. Only the following fire hydrants and valve boxes listed shall be accepted for construction.
 - Fire Hydrants:
 - Mueller Modern Centurion
 - Mueller Centurion Model 423
 - Waterous Pacer WB-67-250
 - Valve Boxes
 - Tyler Screw-Type "C" cast iron valve box assembly series 6860 with No. 160 oval base.
 - Clay & Bailey Screw-Type 6-inch cast iron valve box assembly No. P-108 with No. 160 large oval base.
11. The contractor is responsible for:
 - Notifying all customers possibly affected by outage of water during construction.
 - Contacting Kennedy/Jenks Consultants for inspection, 303-985-3636, at least 24 hours prior to commencing construction.
12. In case of an emergency after working hours, call the District at 303-688-8550.
13. Prior to installation of water mains, road construction must have progressed to at least the "sub-grade" stage. Sub-grade is defined as an elevation of no more than seven inches below the finished street grade. All valve boxes and fire hydrants shall be adjusted to final finished grade by the contractor.
14. Before any taps are made from mains, application for said taps (Connection Permit application) must be received and approved by the Castle Pines North Metropolitan District.
15. All taps will be made by a contractor pre-approved by the Castle Pines North Metropolitan District. All taps must be inspected by the Castle Pines North Metropolitan District.
16. Meter locations shall be approved by the Castle Pines North Metropolitan District. It is the developer's responsibility to contact the District at (303) 688-8550.

17. Meters for domestic and commercial services shall be located inside the building per District details 30A-W and 31W. Meters for separate irrigation and certain multi-family services shall be located in concrete pits or vaults per District details 30B-W and 32W. Meter remote read locations shall be approved by the Castle Pines North Metropolitan District. It is the developer's responsibility to contact the District at (303) 688-8550.
18. Call (303) 688-8550 to schedule an on site pre-construction meeting for all meter settings 1-1/2 inch or larger.
19. Individual service line PRVs are required (when area pressure exceeds 80 psi).
20. A backflow prevention device approved by Castle Pines North Metropolitan District is required on the treated water service line for:
 - All commercial and multi-family domestic taps.
 - Taps where there is a dual water supply on the premises.
 - Fire lines.
 - Irrigation lines.
21. Final conveyance of facilities is dependent on completion of all road way improvements. Successful completion of a minimum two (2) year probation period and all conditions as outlined on the probation/conveyance documents.
22. The developer is responsible for maintenance of the system from probation to final conveyance. Failure to maintain water lines by the terms of the probation agreement may be considered grounds for permanent abandonment of facilities.
23. 12-gauge tracer wire shall be installed on all water mains per District detail.
24. The District, its representative, and/or the District Engineer, is not a guarantor of the construction Contractors' obligations and performance of contract.
25. Observations of work in progress and on-site visits are not to be construed as a guarantee by the District or District Engineer, of the Contractors' performance.
26. The District and/or District Engineer, is not responsible for safety in, on, or about the Project site, nor for compliance by the appropriate party of any regulations relating thereto.
27. The District and/or District Engineer, exercises no control of the safety or adequacy of any equipment, building components, scaffolding, forms, or any other work aids used in or about the project, or in the superintending of the same.

19. CPNMD DETAIL DRAWINGS

<u>Detail No.</u>	<u>Detail Name</u>
1W	Standard Bedding for Water Lines
2W	Not Used
3W	Special Bedding for Water Lines
4W	Length of Restrained Pipe
5W	Polyethylene Wrap
6W	Kickblock
7W	Mechanical Joint Restraint
8W	Tracer Wire Installation
9W	Tracer Wire Test Station at Valve
10W	Gate Valve
11W	Fire Hydrant Assembly
12W	Fire Hydrant Guards
13W	2-inch Blow-off Assembly
14W	6-inch Blow-off Assembly (2 sheets)
15W	Tapping Tee and Valve
16W	Clamp Detail and Dimensions
17W	Direct Bury Butterfly Valve
18W	Butterfly Valve and Vault Assembly
19W	Air Release Valve and Vault
20W	Residential Vent Pipe
21W	PVC Vent Pipe
22W	Plastic Manhole Step
23W	24" Ring and Cover
24W	36" x 24" Double Ring and Cover
25W	Wall Clamp
26W	Conduit Crossing
27W	Water Line Crossing Existing Sewer
28W	Concrete Encasement
29W	Domestic Water Tapping
30A-W	Domestic Water Service (Inside Setting)
30B-W	Water Service (¾" and 1" Outside Setting)
31W	Commercial Water Service
32W	1-1/2" and 2" Irrigation Meter Vault
33W	Remote Transponder Installation on Outside Wall
34W	Domestic Water Service Reconnection
35W	Standard Steel Marker Post
36W	Carsonite Marker Post
37W	Redwood Marker Post
38W	Pipe Casing and Sled – Polymer Runners, Restrained Casing Spacers
39W	Pipe Casing and Sled – Polymer Runners, Restrained Water Main
40W	Not Used
41W	Pressure Regulating Valve (2 sheets)
42W	Pipe Abandonment
43W	Water Vault Abandonment
---	Fire Department Approval Block

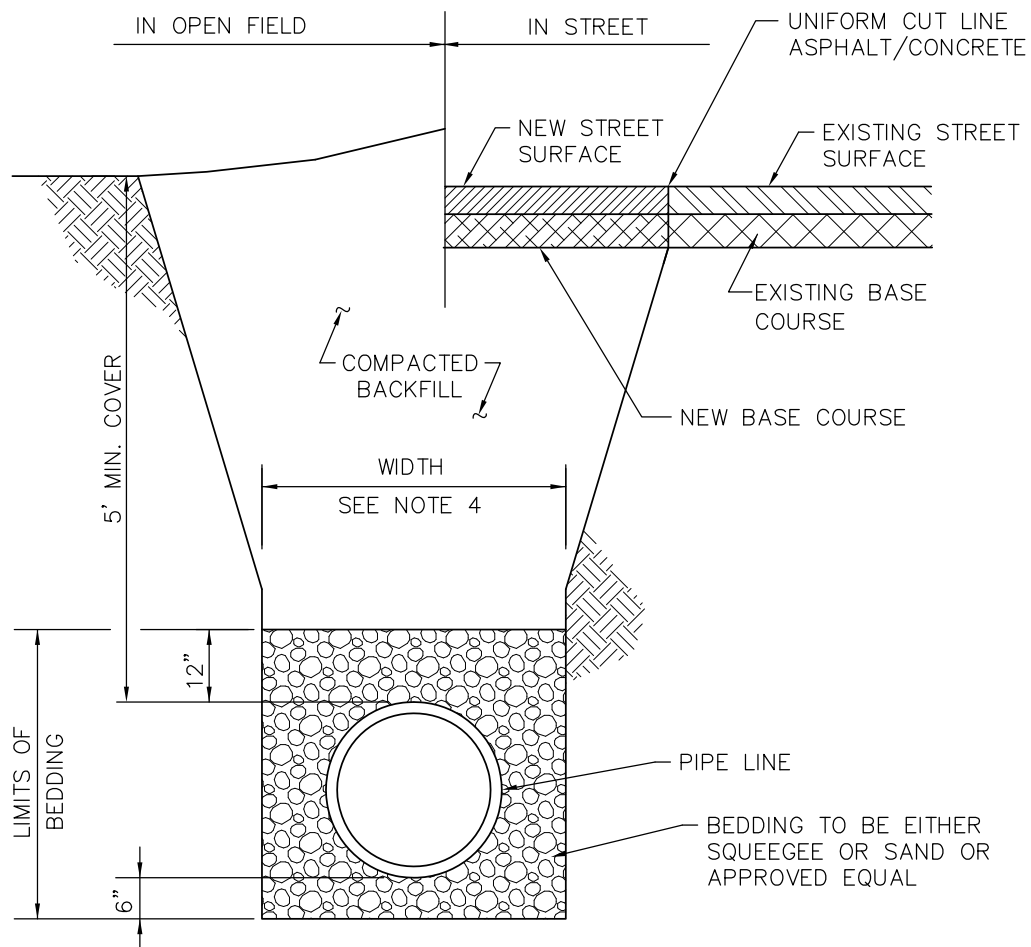

TYPICAL TRENCH SECTION

NOTES:

1. MINIMUM COVER TO BE 5' BELOW FINAL PAVEMENT GRADE.
2. THE TRENCH SHALL BE IN ACCORDANCE WITH APPLICABLE LOCAL, STATE, AND FEDERAL SAFETY REGULATIONS.
3. PIPE SHALL BE BEDDED FROM 6" BELOW THE BOTTOM OF THE PIPE TO 12" ABOVE THE PIPE.
4. TRENCH WIDTH SHALL NOT BE MORE THAN 16" NOR LESS THAN 12" WIDER THAN THE LARGEST OUTSIDE DIAMETER OF THE PIPE.
5. SHOULD THE TRENCH BE EXCAVATED WIDER THAN ALLOWED, A CONCRETE CRADLE SHALL BE PLACED WITH 2500 p.s.i. CONCRETE FROM TRENCH BOTTOM TO PIPE SPRINGLINE (SEE SPECIAL BEDDING DETAILS).
6. COMPACTION SHALL BE 95% S.P.D. IN STREET R.O.W.; OUTSIDE OF STREET R.O.W. SHALL BE 90% S.P.D. PIPE BEDDING SHALL BE COMPACTED TO 90% S.P.D.

**STANDARD BEDDING
FOR WATER LINES**

M *Castle Pines North*
METROPOLITAN DISTRICT

Kennedy/Jenks Consultants
Engineers & Scientists

NOT USED



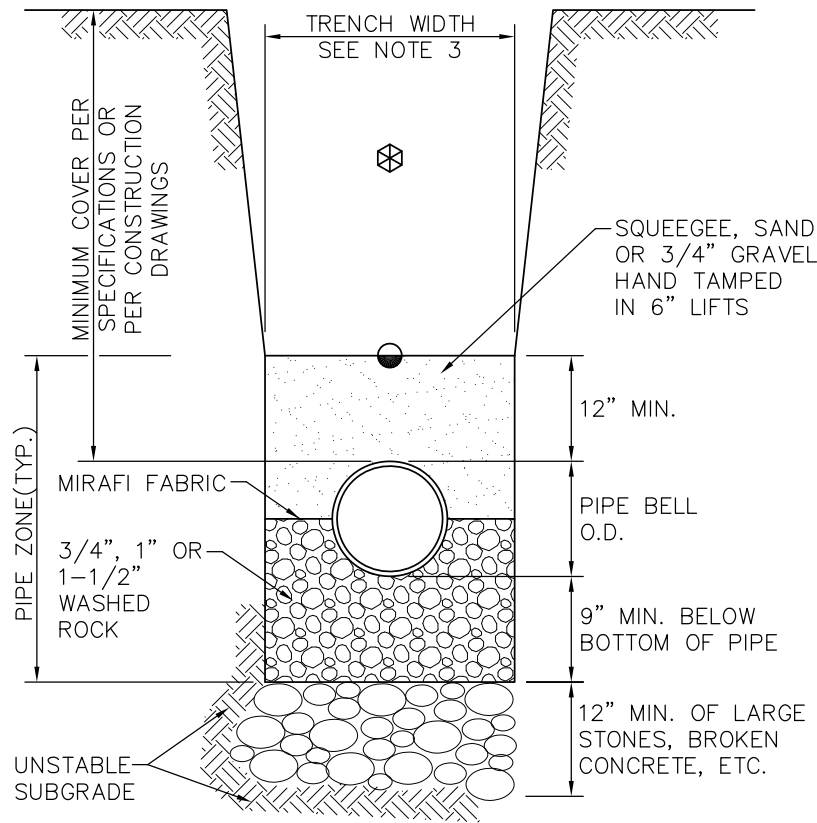

UNSTABLE SUBGRADE

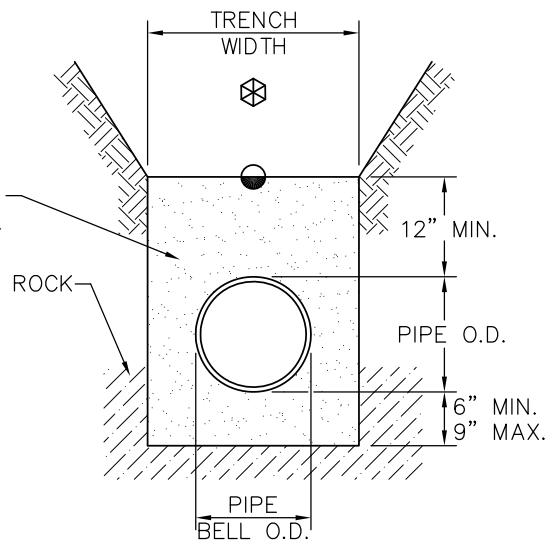

PIPE BEDDING IN ROCK

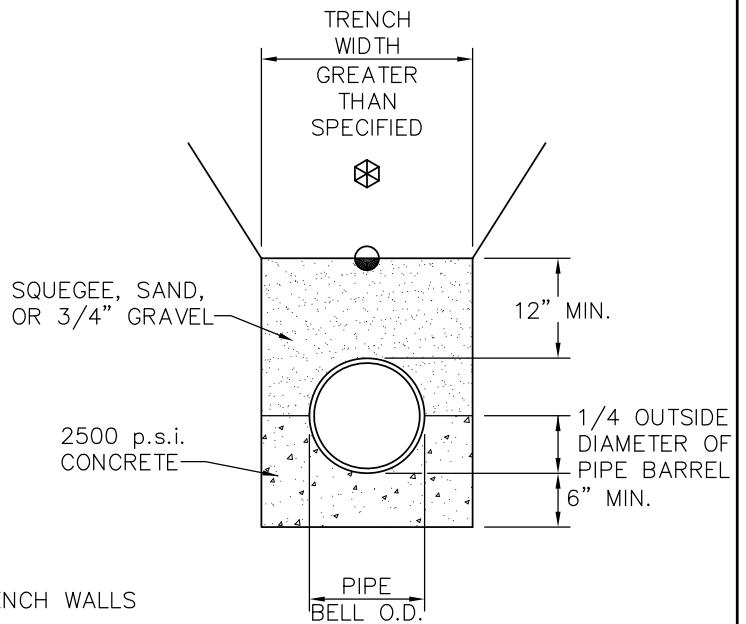

TRENCH OVERWIDTH



MACHINE COMPACTED TRENCH BACKFILL



LIMITS OF SLOPING OR BENCHING OF TRENCH WALLS

UNDISTURBED GROUND

NOTES:

1. MIN. COVER TO BE 5' BELOW FINAL STREET GRADE WHEN AVAILABLE.
2. THE TRENCH SHALL BE IN ACCORDANCE WITH APPLICABLE LOCAL, STATE, AND FEDERAL SAFETY REGULATIONS.
3. TRENCH WIDTH SHALL NOT BE MORE THAN 16 INCHES NOR LESS THAN 12 INCHES WIDER THAN THE LARGEST OUTSIDE DIAMETER OF THE PIPE LAID THEREIN (BELL OR COUPLING O.D. IF APPLICABLE).

**SPECIAL BEDDING
FOR WATER LINES**

**Castle Pines North
METROPOLITAN DISTRICT**

**Kennedy/Jenks Consultants
Engineers & Scientists**

PIPE SIZE	4"			6"			8"			12"			16"			20"			24"		
	D	L	G	D	L	G	D	L	G	D	L	G	D	L	G	D	L	G	D	L	G
TEE OR VALVE	3/4"	30'	M.S.	3/4"	45'	M.S.	3/4"	60'	M.S.	3/4"	86'	H.S.	1"	108'	H.S.	1 1/2"	132'	H.S.	-	155'	-
PLUG OR 90° BEND	3/4"	30'	M.S.	3/4"	45'	M.S.	3/4"	60'	M.S.	3/4"	86'	H.S.	1"	108'	H.S.	1 1/2"	132'	H.S.	-	155'	-
45° BEND	3/4"	9'	M.S.	3/4"	13'	M.S.	3/4"	18'	M.S.	3/4"	25'	M.S.	1"	32'	M.S.	3/4"	39'	H.S.	-	45'	-
22.5° BEND	3/4"	1'	M.S.	3/4"	4'	M.S.	3/4"	5'	M.S.	3/4"	7'	M.S.	3/4"	8'	M.S.	3/4"	10'	M.S.	-	12'	-
11.25° BEND	-	-	-	-	-	-	3/4"	1'	M.S.	3/4"	2'	M.S.	3/4"	2'	M.S.	3/4"	3'	M.S.	-	3'	-

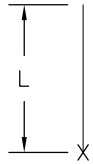

VALVE OR PLUG

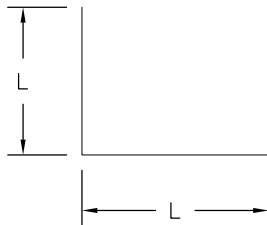

90° BEND

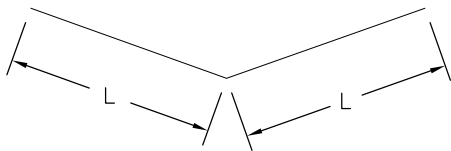

BENDS

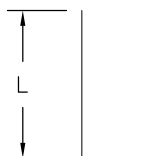

TEE

NOTES:

- 1- LENGTHS OF TIED PIPE MEASURED EACH WAY FROM VALVES AND BENDS.
- 2- CLAMPS AND RODS NOT ALLOWED FOR 24" AND LARGER PIPES.
- 3- D=DIAMETER,L=LENGTH,G=GRADE
M.S.=MILD STEEL,H.S.=HIGH STRENGTH
- 4- MINIMUM 4.5' GROUND COVER REQUIRED.
- 5- BASED ON 150 PSI INTERNAL PRESSURE
- 6- M.S. MEANS MILD STEEL ROD A.S.T.M. STANDARD DESIGNATION A-36.
- 7- H.S. MEANS HIGH STRENGTH ROD A.S.T.M. STANDARD DESIGNATION A-193 GRADE B-7.
- 8- NUTS SHALL BE A.S.T.M. STANDARD DESIGNATION A-307 GRADE A OR B HEXAGON HEAVY SERIES.
- 9- SEE TIE ROD DETAIL DRAWING.ALSO,TIE ROD COUPLING DETAILS, CLAMP DETAILS AND SET CLAMP DETAILS.
- 10-LENGTH REFERS TO THE AMOUNT OF PIPE WHICH MUST BE TIED TOGETHER AND IS NOT NECESSARILY THE LENGTH OF THE RODS.
- 11-IN GENERAL, THE FOLLOWING ITEMS ARE TO BE RESTRAINED:
 - A) ALL HORIZONTAL BENDS
 - B) ALL VERTICAL BENDS
 - C) PLUGS/DEAD ENDS
 - D) BRANCHES ON TEES
 - E) FIRE HYDRANTS PER DETAIL
 - F) VALVES ON 24 INCH & LARGER PIPE
 - G) CROSSES (IN ALL APPLICABLE DIRECTIONS)
 - H) DISTRICT REPRESENTATIVE MAY REQUIRE OTHER ITEMS TO BE RESTRAINED
- 12-12" AND SMALLER IN-LINE VALVES AND TEES SHALL HAVE A MECHANICAL JOINT RESTRAINT DEVICE ON EACH SIDE OF THE FITTING OR VALVE.
- 13-LENGTH OF RESTRAINED PIPE CHART IS ALSO FOR THE LENGTH OF JOINT RESTRAINT FOR MEGALUGS.
- 14-A SECOND VALVE WILL BE REQUIRED TO BE CLOSED DOWN WHEN EXCAVATING NEXT TO AN EXISTING VALVE.

LENGTH OF RESTRAINED PIPE

Castle Pines North
METROPOLITAN DISTRICT

Kennedy/Jenks Consultants
Engineers & Scientists

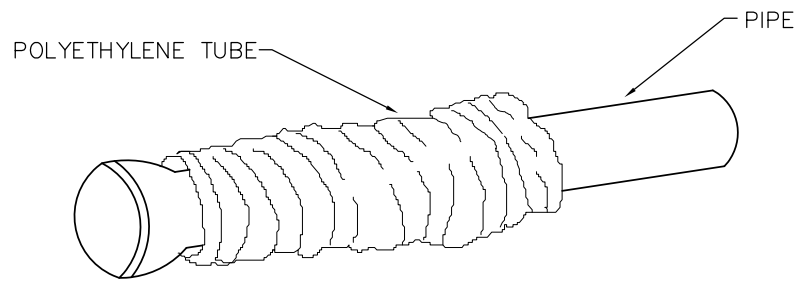

STEP 1

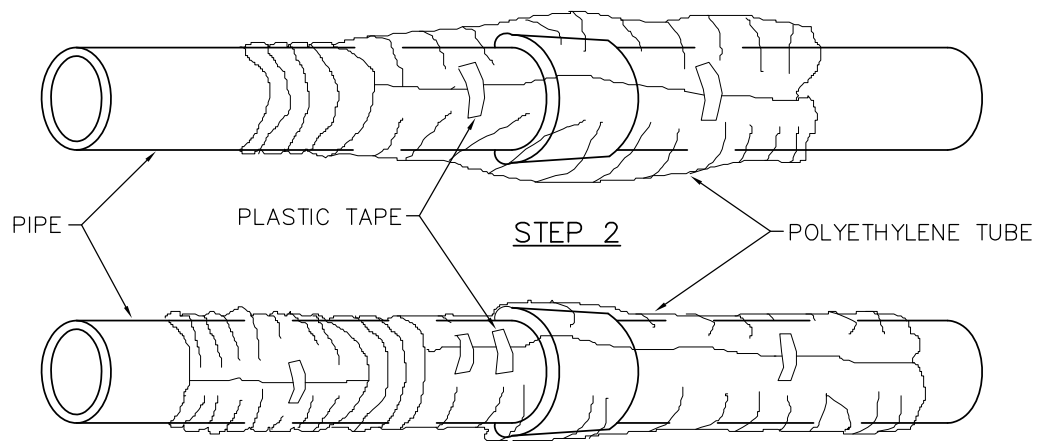

STEP 3

FIELD INSTALLATION – POLYETHYLENE WRAP

- STEP 1– PLACE TUBE OF POLYETHYLENE MATERIAL ON PIPE PRIOR TO LOWERING IT INTO TRENCH.
- STEP 2– PULL THE TUBE OVER THE LENGTH OF THE PIPE. TAPE TUBE TO PIPE AT JOINT. FOLD MATERIAL AROUND THE ADJACENT SPIGOT END AND WRAP WITH TAPE TO HOLD THE PLASTIC TUBE IN PLACE.
- STEP 3– OVERLAP FIRST TUBE WITH ADJACENT TUBE AND SECURE WITH PLASTIC ADHESIVE TAPE. THE POLYETHYLENE TUBE MATERIAL COVERING THE PIPE SHALL BE LOOSE. EXCESS MATERIAL SHALL BE NEATLY DRAWN UP AROUND THE PIPE BARREL, FOLDED ON TOP OF PIPE AND TAPED IN PLACE.

NOTE:

ALL BURIED DUCTILE IRON PIPE, FITTINGS, VALVES, FIRE HYDRANT ASSEMBLIES, AND RODDING SHALL BE POLYETHYLENE WRAPPED.

POLYETHYLENE WRAP

M *Castle Pines North*
METROPOLITAN DISTRICT

Kennedy/Jenks Consultants
Engineers & Scientists

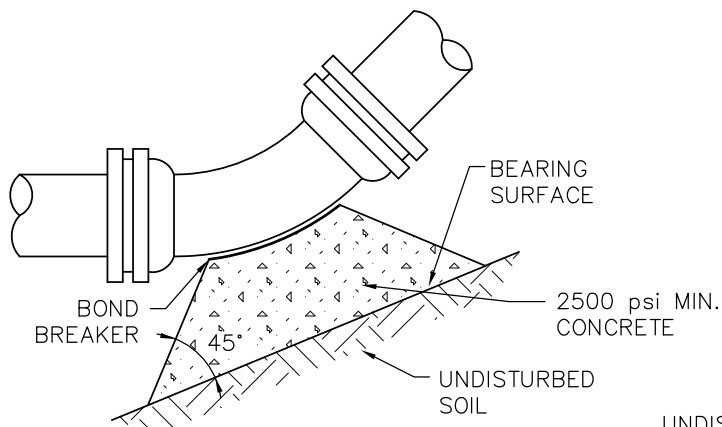

11.25°, 22.5° AND 45° BENDS

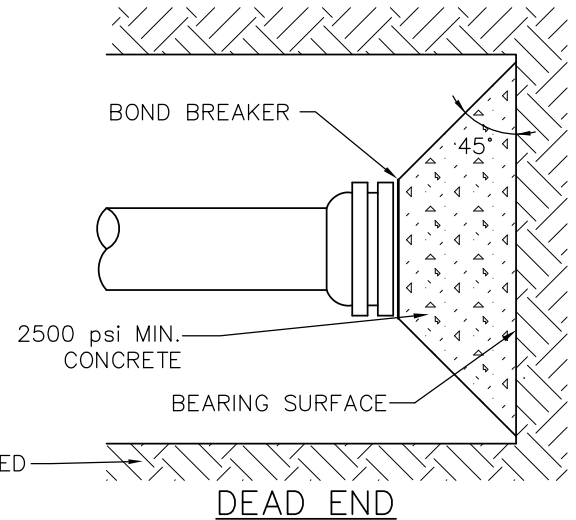

DEAD END

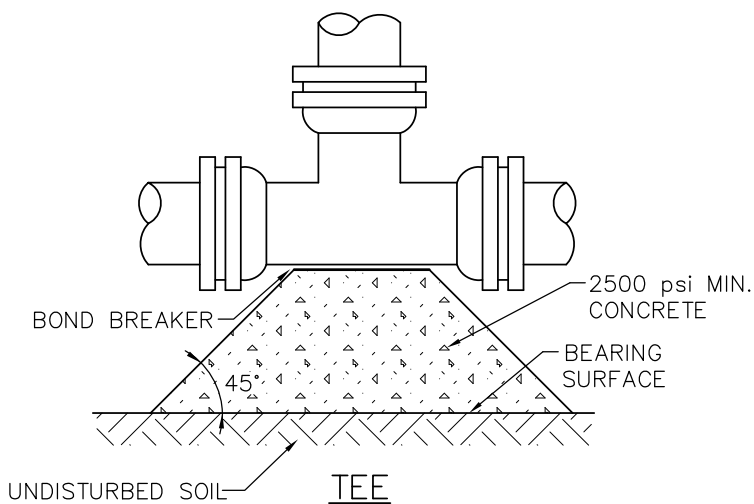

TEE

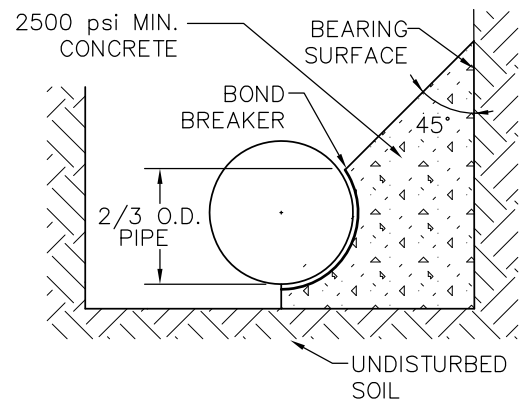

TYPICAL CROSS SECTION

NOTES:

- 1-ALL BENDS, TEES, AND DEAD ENDS SHALL BE BOTH MECHANICALLY RESTRAINED AND KICKBLOCKED.
- 2-BEARING SURFACE AREAS SHOWN IN CHART ARE MINIMUM.
- 3-BASED ON 150 PSI INTERNAL PIPE PRESSURE PLUS WATER HAMMER.
 4", 6" AND 8" WATER HAMMER= 120 P.S.I.
 12" WATER HAMMER= 110 P.S.I.
 16" AND 20" WATER HAMMER= 70 P.S.I.
- 4-SOIL BEARING CAPACITY = 3,000 LB / SQ. FT.
- 5-ALL 90° BENDS SHALL BE RODDED.
- 6-NA = NOT APPLICABLE.

MINIMUM BEARING SURFACE AREA
(IN SQUARE FEET)

SIZE OF PIPE	B E N D S				TEE OR DEAD END
	11.25°	22.5°	45°	90°	
4"	1.00	1.00	1.00	2.00	1.50
6"	1.00	1.25	2.25	4.25	3.00
8"	1.00	2.00	4.00	7.50	5.25
12"	2.25	4.50	8.75	16.00	11.25
16"	3.75	7.50	14.50	27.00	19.00
20"	5.00	10.00	19.50	35.50	25.00
24"	7.00	14.00	27.75	51.00	36.00

KICKBLOCK

Castle Pines North METROPOLITAN DISTRICT

Kennedy/Jenks Consultants
Engineers & Scientists

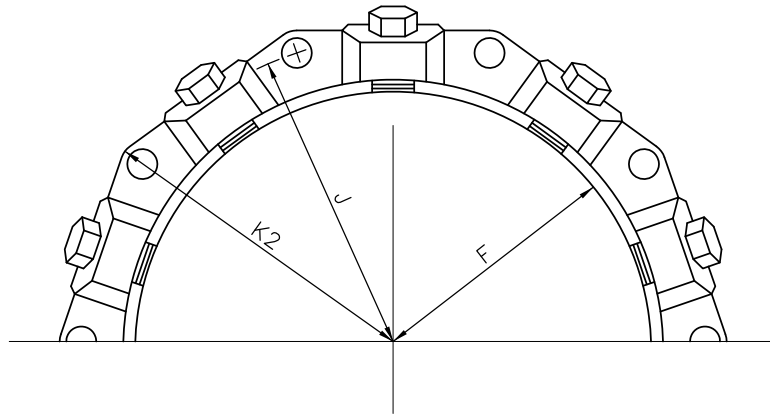

MECHANICAL JOINT RESTRAINT

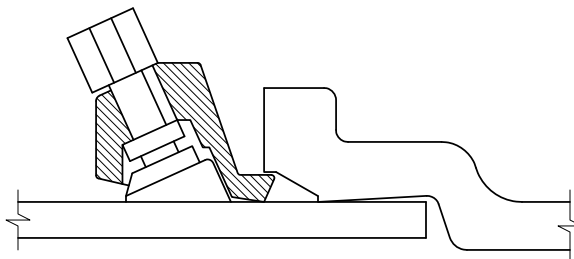

WEDGE DETAIL

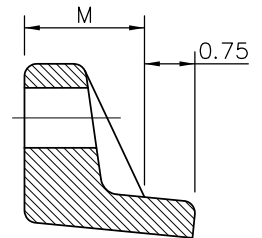

BOLT HOLE DETAIL

DIMENSIONS

	NOMINAL PIPE SIZE	NO. OF BOLTS	NO. OF WEDGES	K2 INCHES	J INCHES	F INCHES	M INCHES	
P V C	4"	2	2					P V C
	6"	6	3	11.12	9.50	7.00	0.88	
	8"	6	4	13.37	11.75	9.15	1.00	
	10"	8	6	15.62	14.00	11.20	1.00	
	12"	8	8	17.88	16.25	13.30	1.25	
D I	4"	4	2					D I
	6"	6	3	11.12	9.50	7.00	0.88	
	8"	6	4	13.37	11.75	9.15	1.00	
	10"	8	6	15.62	14.00	11.20	1.00	
	12"	8	8	17.88	16.25	13.30	1.25	

DIMENSIONS FOR 16" AND 20" D.I. PIPE NOT SHOWN

NOTE:

USE EBBA IRON "MEGALUG", SERIES 1100 (D.I.P.), SERIES 1100PV (P.V.C.)
OR APPROVED EQUAL

**MECHANICAL JOINT
RESTRAINT**

**Castle Pines North
METROPOLITAN DISTRICT**

**Kennedy/Jenks Consultants
Engineers & Scientists**

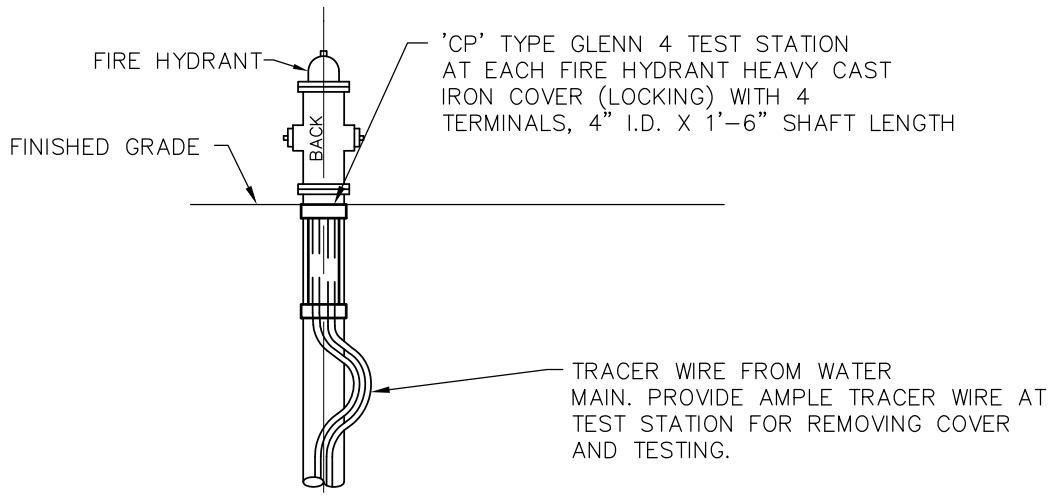

PROFILE

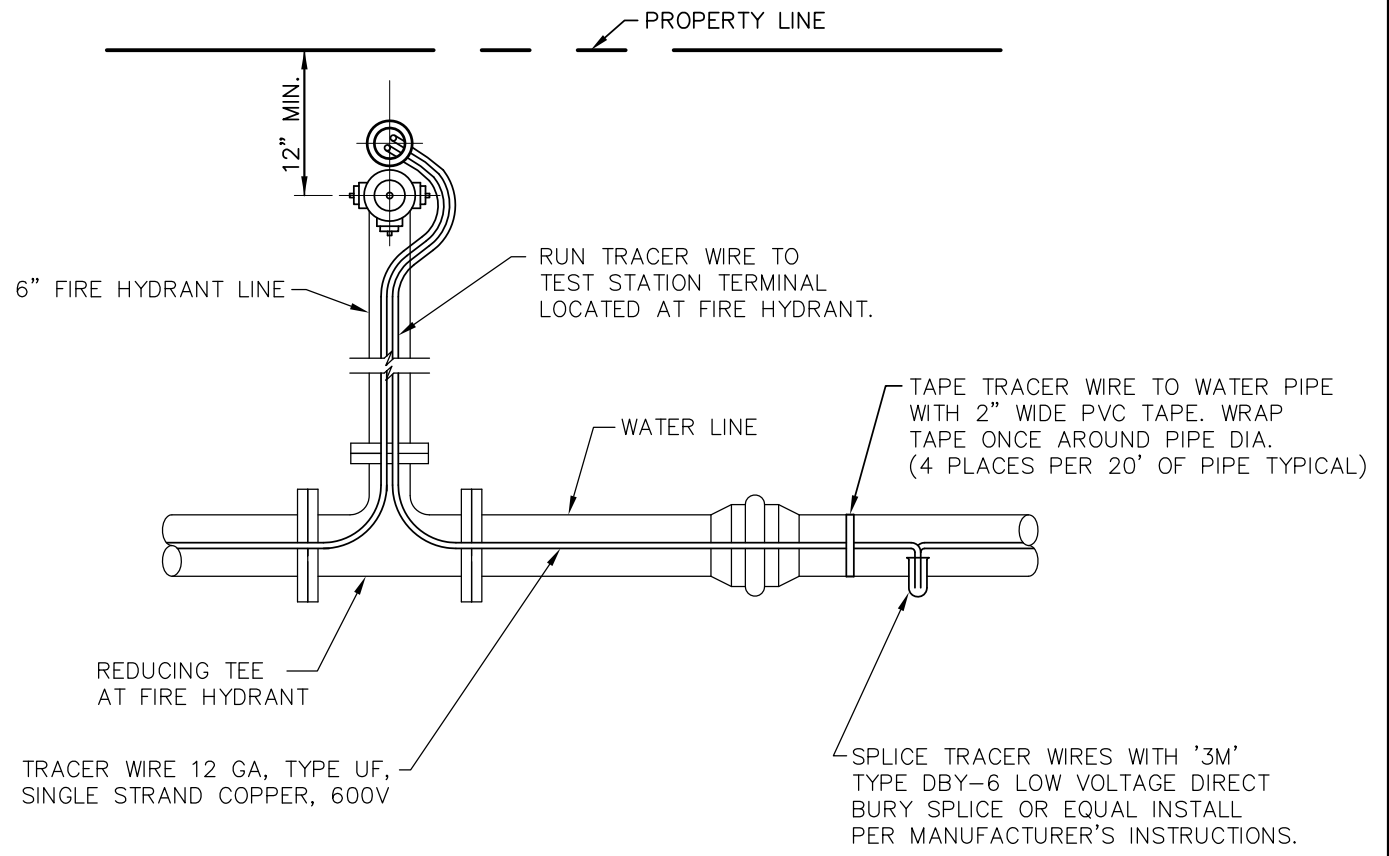

PLAN VIEW

TRACER WIRE INSTALLATION

Castle Pines North METROPOLITAN DISTRICT

Kennedy/Jenks Consultants
Engineers & Scientists

18"x36"x6" THICK CONC. COLLAR REQUIRED OUTSIDE OF PAVEMENT. VALVE BOX & TEST STATION RATED FOR TRAFFIC IN PAVEMENT.

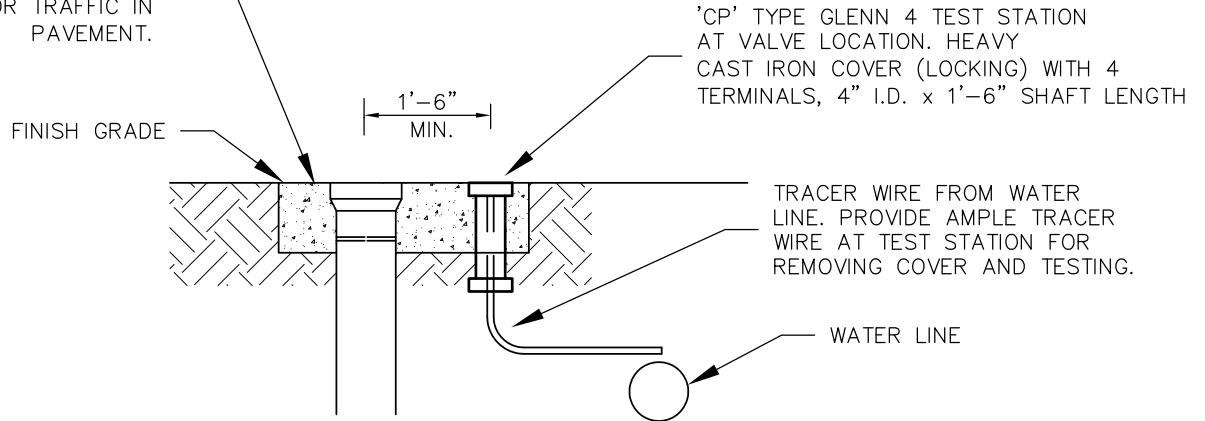

PROFILE

SPLICE TRACER WIRES WITH '3M' TYPE DBY-6 LOW VOLTAGE DIRECT BURY SPLICE OR EQUAL INSTALL PER MANUFACTURER'S INSTRUCTIONS

TAPE TRACER WIRE TO PIPE WITH 2" WIDE PVC TAPE. WRAP TAPE ONCE AROUND PIPE DIA. (4 PLACES PER 20' OF PIPE TYPICAL)

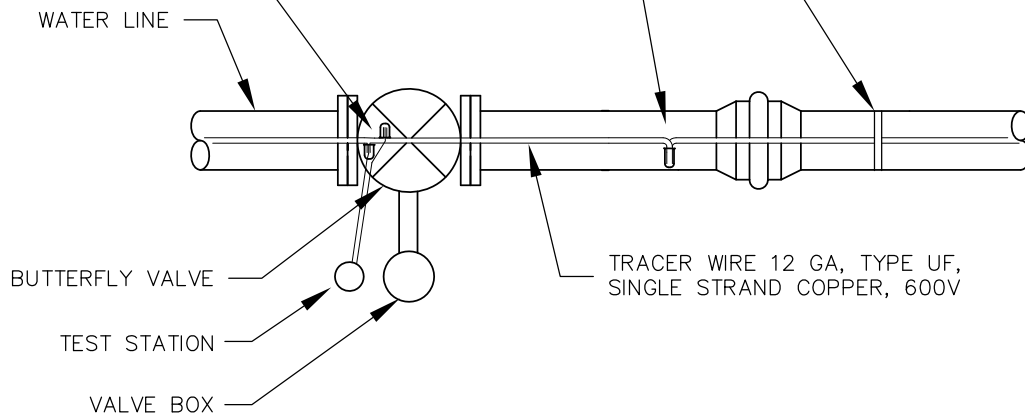

PLAN VIEW

NOTE: THIS DETAIL APPLIES TO LARGE DIAMETER WATER TRANSMISSION MAINS WITH VERY FEW FIRE HYDRANTS FOR TRACER WIRE TEST STATIONS.

**TRACER WIRE TEST STATION
AT WATER VALVE**

**Castle Pines North
METROPOLITAN DISTRICT**

Kennedy/Jenks Consultants
Engineers & Scientists

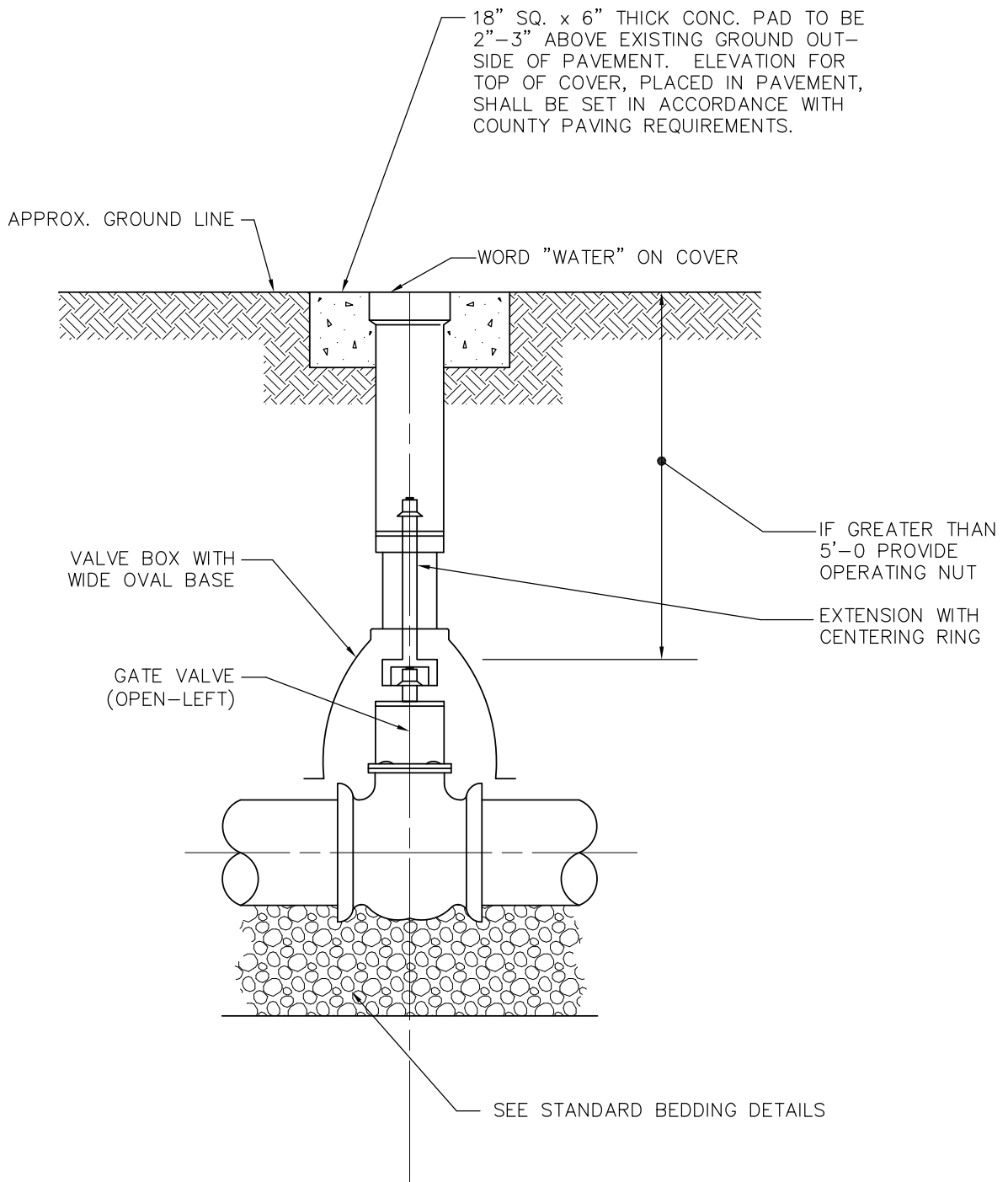

NOTE:
 CARE SHALL BE TAKEN WHEN INSTALLING VALVES ON LINES TO ASSURE PROPER SUPPORT OF THE VALVES. THE ENGINEER WILL REQUIRE 3/4" WASHED ROCK TO BE INSTALLED UNDER THE VALVE TO PROVIDE PROPER SUPPORT WHERE REQUIRED. VALVES SHALL NOT BE PLACED IN CONCRETE CROSS PANS.

GATE VALVE

Castle Pines North
METROPOLITAN DISTRICT

Kennedy/Jenks Consultants
 Engineers & Scientists

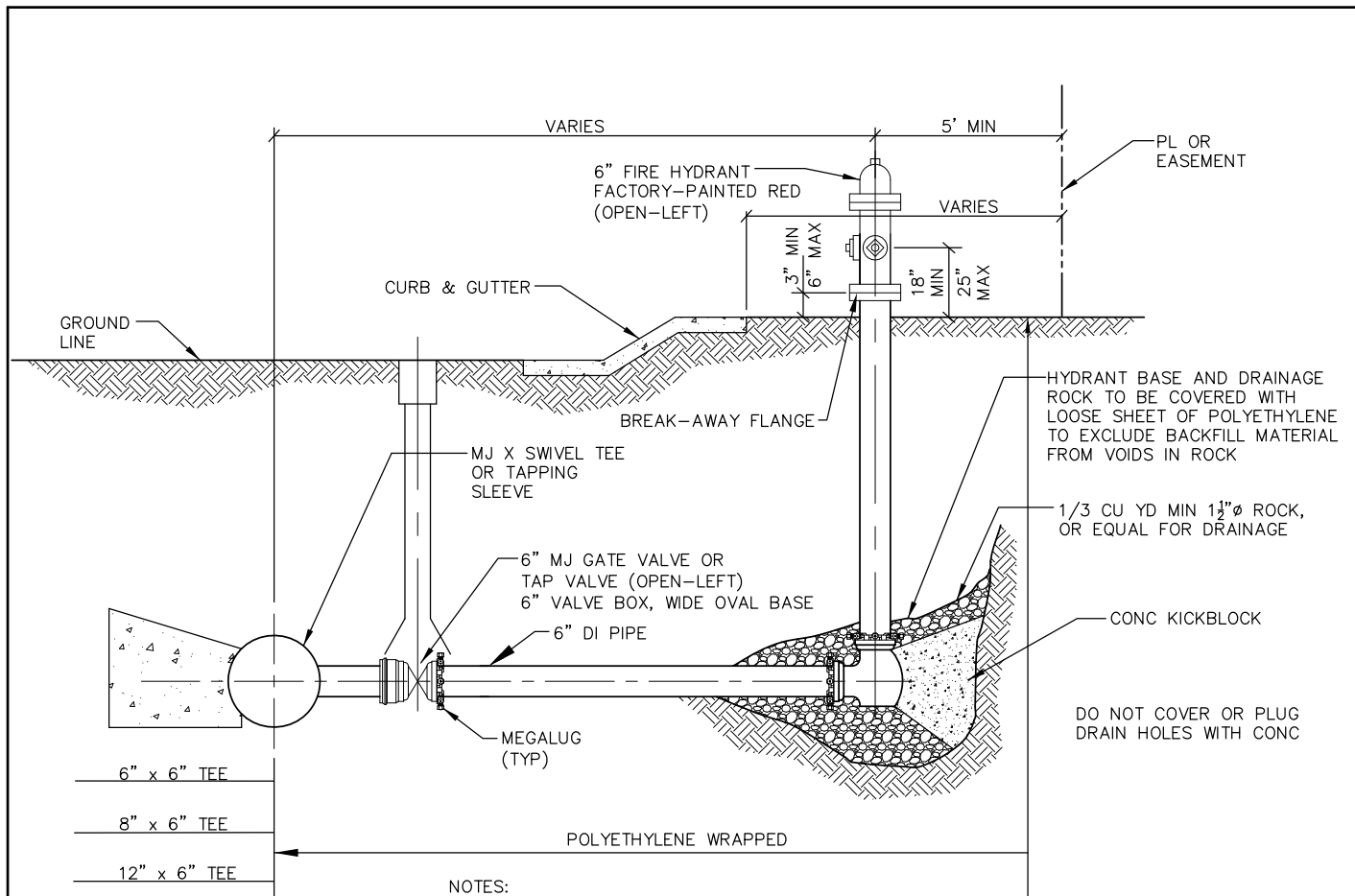

NOTES:

1. NO HORIZONTAL OR VERTICAL BENDS ARE PERMITTED IN FIRE HYDRANT BRANCH OR FIRE LINES.
2. ONLY ONE (1) EXTENSION BARREL SECTION IS PERMITTED TO ACHIEVE PROPER CLEARANCE.

MANUFACTURER

MODEL NO.

OPTIONS TO BE FURNISHED

MUELLER COMPANY

MODERN CENTURION

FURNISH STANDARD PRODUCT

MUELLER COMPANY

CENTURION MODEL 423

FURNISH STANDARD PRODUCT

WATEROUS COMPANY

PACER WB-67-250

BRONZE BUSHED SHOE WITH O-RINGS,
FURNISH BRONZE SHAFT COUPLING

THREAD SIZES FOR CONNECTIONS

FIRE DISTRICT	PUMPER CONNECTION	HOSE CONNECTION
S. METRO	6 INCH/DWB	NAT. STD.

FIRE HYDRANT ASSEMBLY



Kennedy/Jenks Consultants
Engineers & Scientists

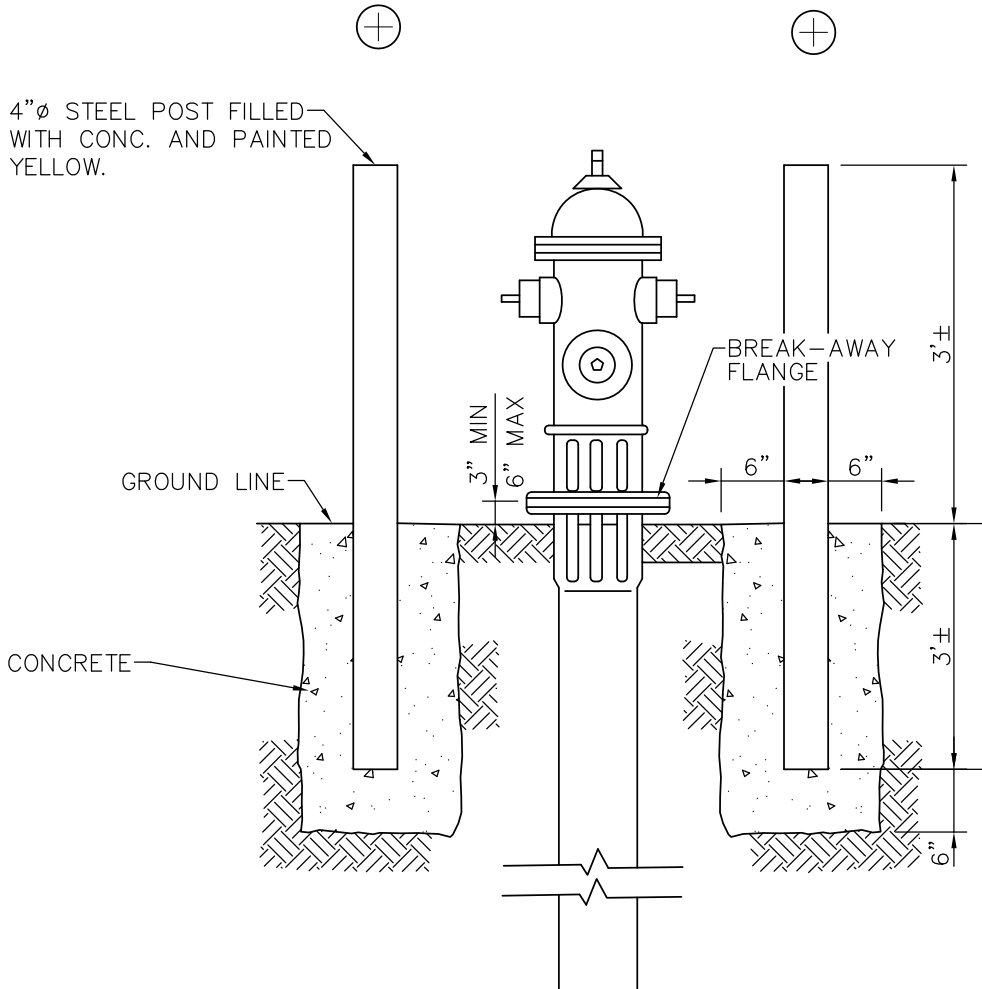
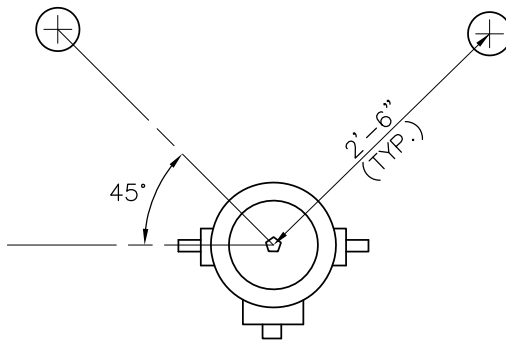

NOTES:

1. TO BE USED IN COMMERCIAL OR INDUSTRIAL AREAS WHERE HYDRANTS ARE UNPROTECTED FROM THE MAIN FLOW OF TRAFFIC.
2. STEAMER CONNECTION ON FIRE HYDRANT SHOULD FACE THE STREET.
3. ONLY ONE (1) EXTENSION BARREL SECTION IS PERMITTED TO ACHIEVE PROPER CLEARANCE.

FIRE HYDRANT GUARDS

M *Castle Pines North*
METROPOLITAN DISTRICT

Kennedy/Jenks Consultants
Engineers & Scientists

NOTE:
 PLUG SHALL BE MECHANICALLY RESTRAINED:
 A—FOR SLEEVE TYPE MACHINED COUPLING
 PIPE, TIE BACK TO NEXT COUPLING
 B—FOR BELL AND SPIGOT PIPE, TIE TO BELL

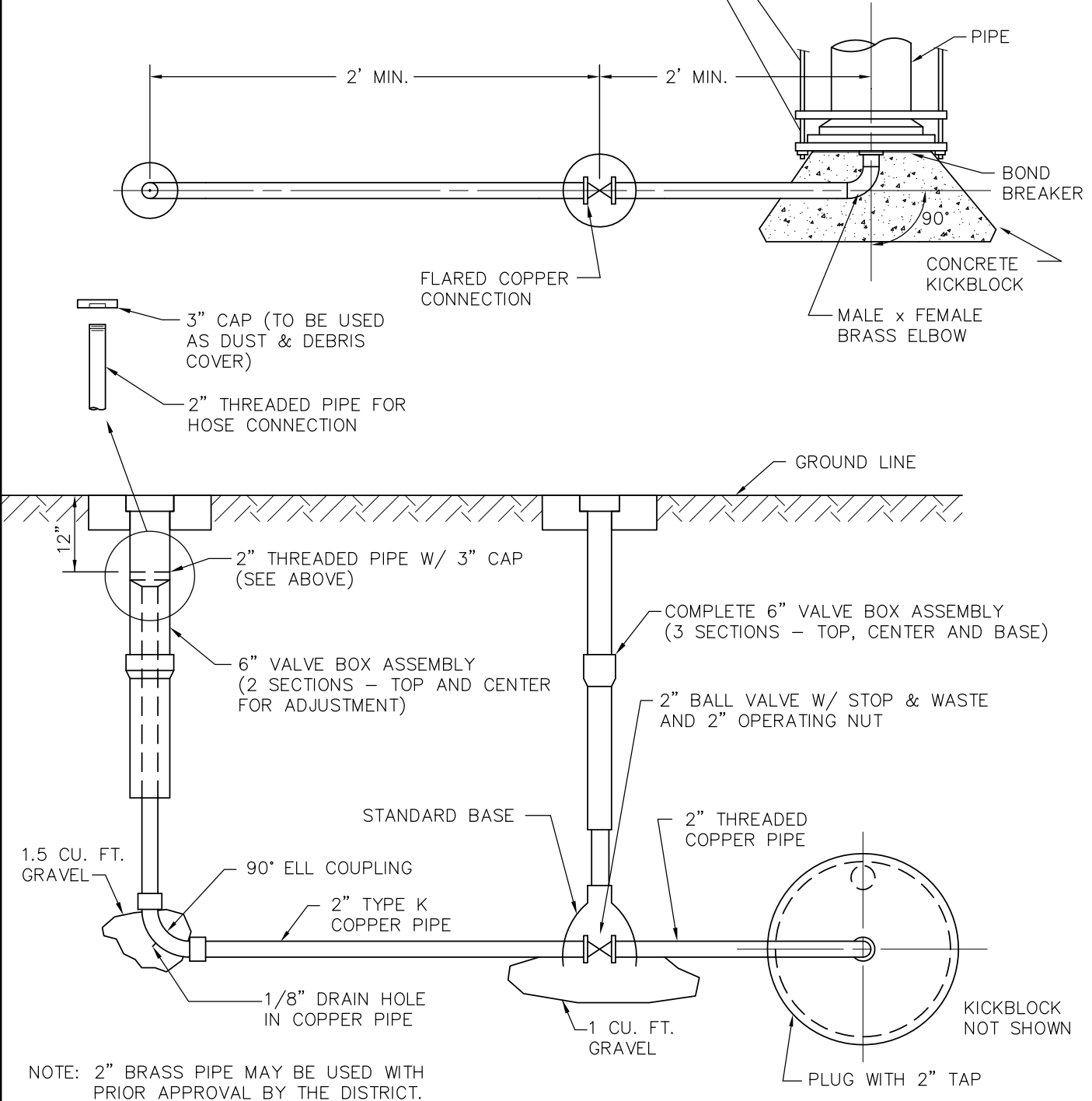

NOTE: 2" BRASS PIPE MAY BE USED WITH
 PRIOR APPROVAL BY THE DISTRICT.

ELEVATION

**2" BLOW-OFF ASSEMBLY
 FOR USE ON MAINS 12" & SMALLER**

**Castle Pines North
 METROPOLITAN DISTRICT**

Kennedy/Jenks Consultants
 Engineers & Scientists

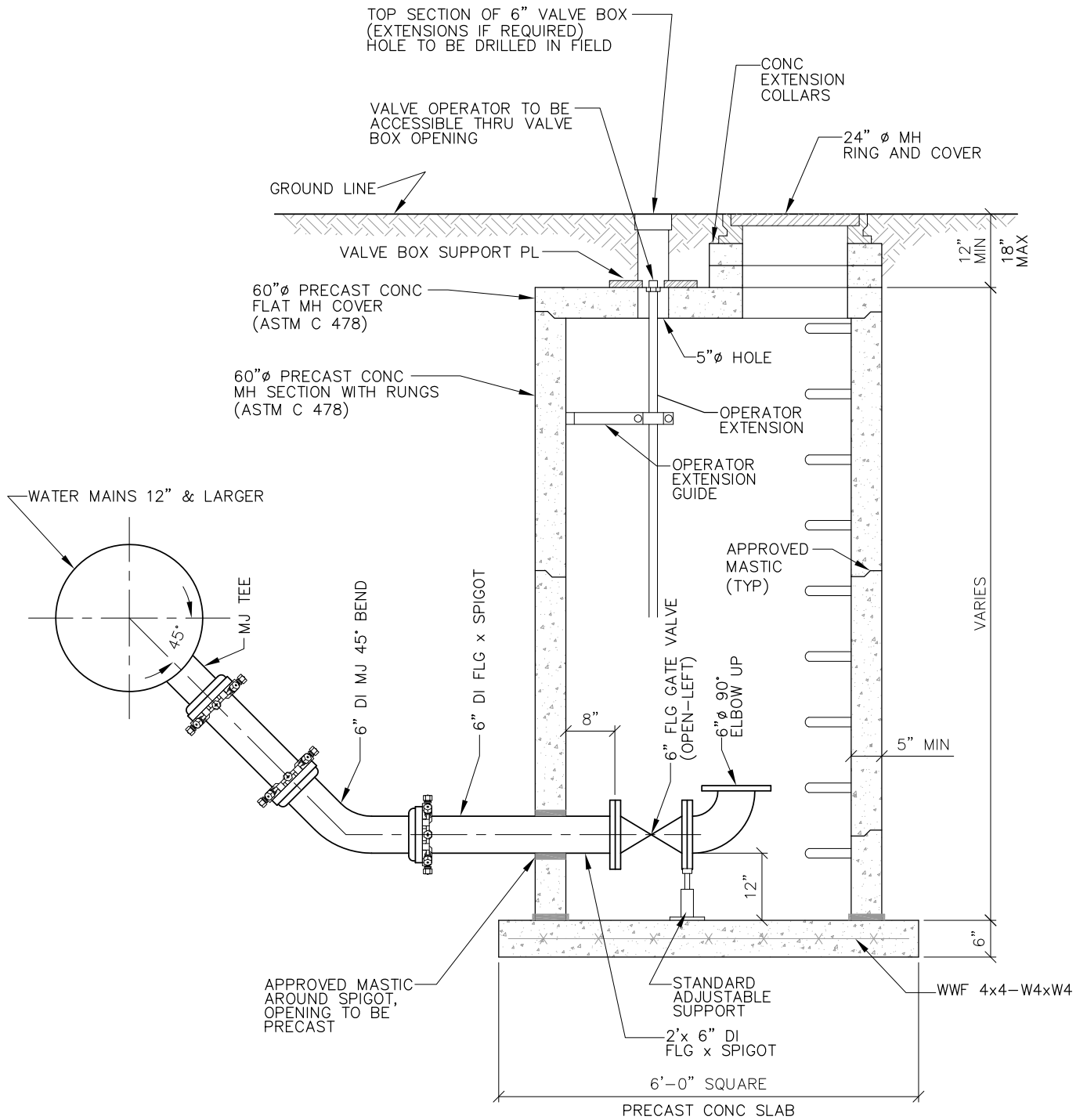

NOTE:

THIS INSTALLATION MAY BE REPLACED BY A FIRE HYDRANT ONLY WHERE APPROVED BY THE DISTRICT.

ELEVATION - 6" BLOW OFF

**6" BLOW-OFF ASSEMBLY
FOR USE ON MAINS 12" & LARGER**

Castle Pines North
METROPOLITAN DISTRICT

Kennedy/Jenks Consultants
Engineers & Scientists

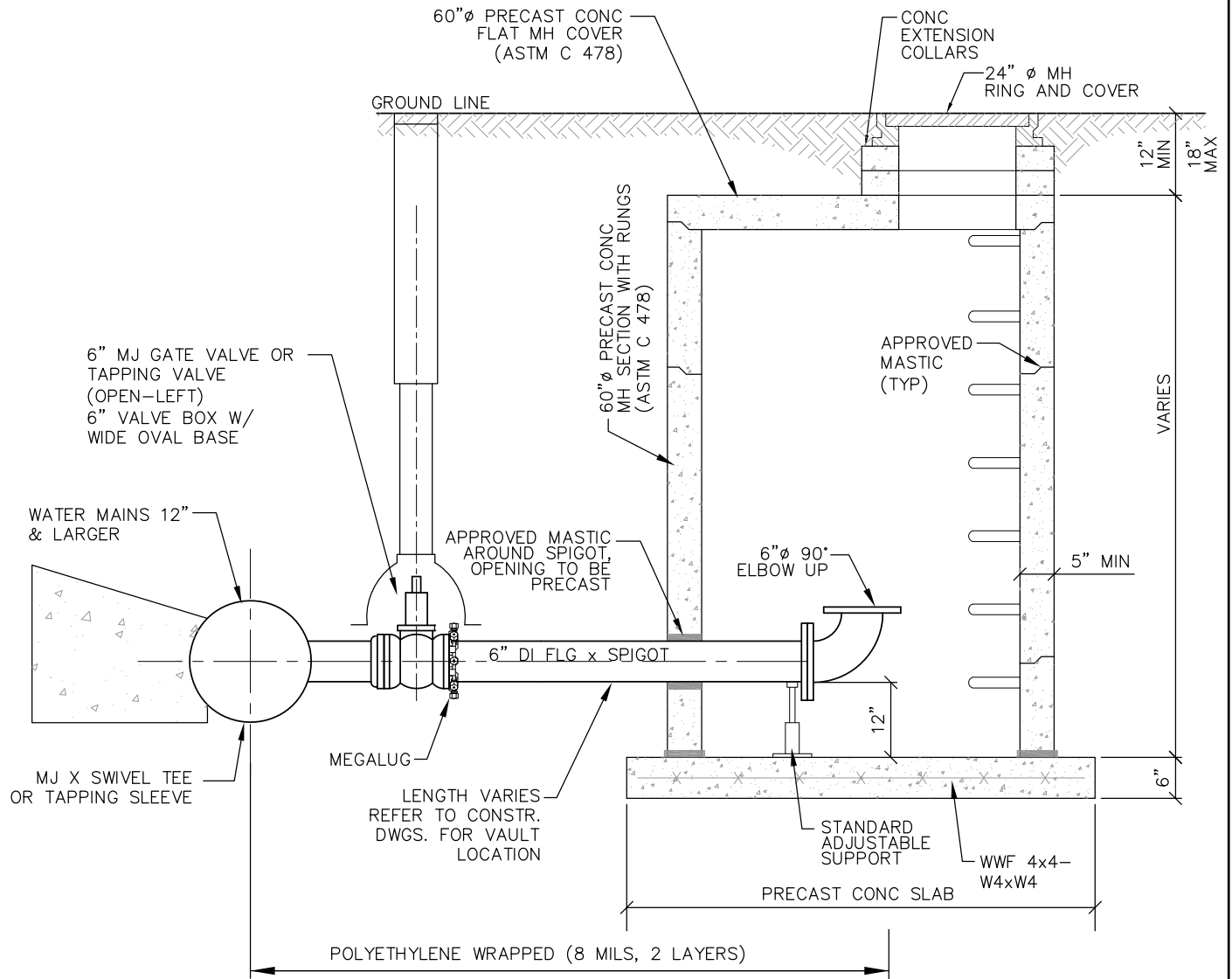

ELEVATION – ALTERNATE 6" BLOW OFF

6" ALT. BLOW-OFF ASSEMBLY
FOR USE ON MAINS 12" & LARGER

Castle Pines North
METROPOLITAN DISTRICT
Kennedy/Jenks Consultants
Engineers & Scientists

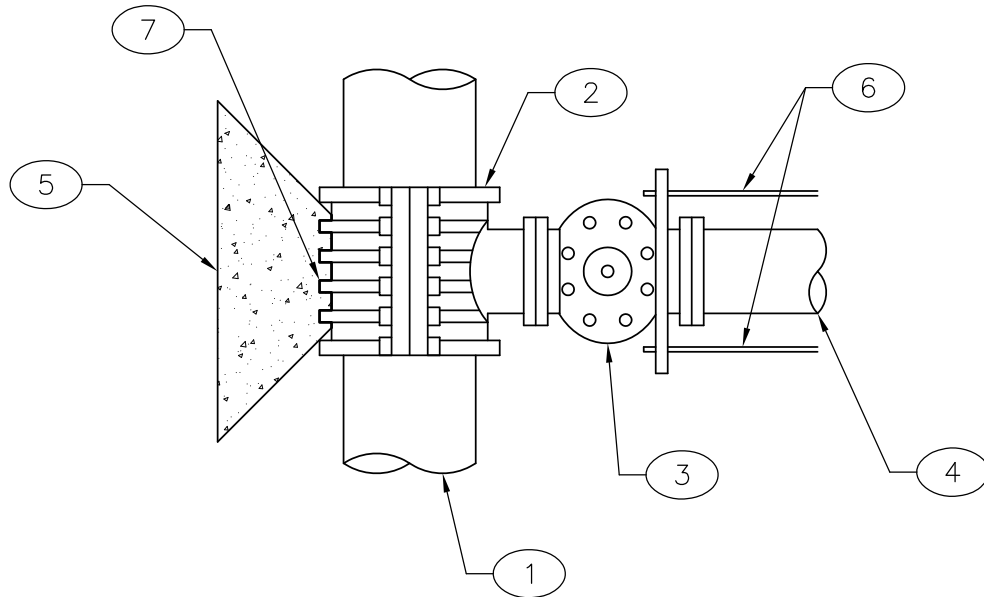

1. EXISTING MAIN
2. FABRICATED STEEL TAPPING SLEEVE WITH EPOXY SHOP COATING, STAINLESS STEEL BOLTS AND NUTS
3. TAPPING VALVE (OPEN-LEFT)
4. DOUBLE SPIGOT PIPE
5. CONCRETE KICKBLOCK (SEE KICKBLOCK DETAIL)
6. TIE RODS (SEE LENGTH OF PIPE RESTRAINT DETAIL) (IF REQUIRED)
7. BOND BREAKER BETWEEN CONCRETE AND WET TAP SADDLE-8 MIL POLYETHYLENE

NOTE:

DISTRICT MUST BE NOTIFIED AT LEAST 24 HOURS BEFORE TAPPING.
 A DISTRICT REPRESENTATIVE MUST BE ONSITE DURING TAPPING.

TAPPING TEE AND VALVE

Castle Pines North
METROPOLITAN DISTRICT

Kennedy/Jenks Consultants
 Engineers & Scientists

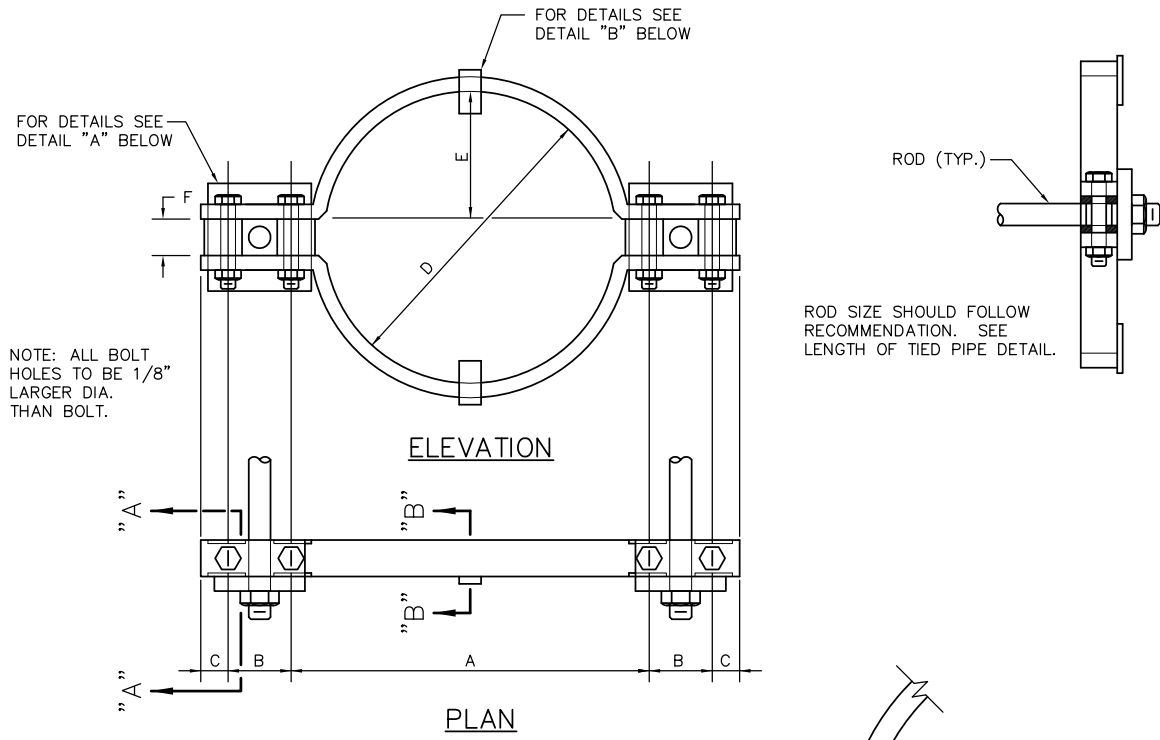

NOTE: ALL BOLT HOLES TO BE 1/8" LARGER DIA. THAN BOLT.

ROD SIZE SHOULD FOLLOW RECOMMENDATION. SEE LENGTH OF TIED PIPE DETAIL.

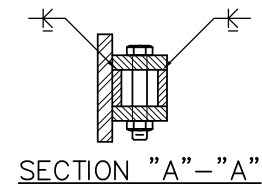

SECTION "A"-"A"

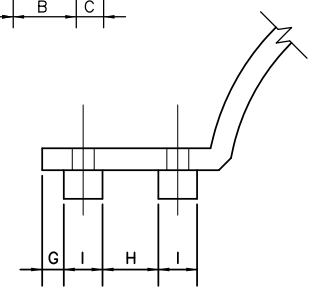

DETAIL A

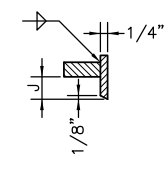

SECTION "B"-"B"

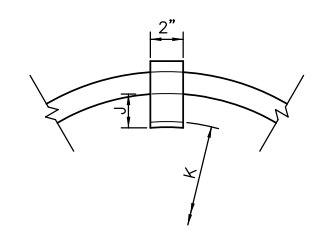

DETAIL B

TABLE OF DIMENSIONS FOR CLAMPS																									
PIPE DIA.	BAR SIZE	A		B		C		D		E		F		G		H		I		J		K		BOLT SIZES	
		BELL CLAMP	BODY CLAMP	BELL CLAMP	BODY CLAMP	BELL CLAMP	BODY CLAMP	BELL CLAMP	BODY CLAMP	BELL CLAMP	BODY CLAMP	BELL CLAMP	BODY CLAMP	BELL CLAMP	BODY CLAMP	BELL CLAMP	BODY CLAMP	BELL CLAMP	BODY CLAMP	BELL CLAMP	BODY CLAMP	BELL CLAMP	BODY CLAMP	BELL CLAMP	BODY CLAMP
4	1 1/2 X 1/2	9	7 3/8	3	4	1 1/2	1 1/2	6 1/4	4 3/4	2 5/8	1 7/8			3/8	3/8	1 1/4	1 1/4	2 1/4	2 1/2	5/8	2 1/2	3 X 1 1/2	2 1/2 X 3/8		
6	2 X 1/2	11 1/4	9 5/8	3	4	1 1/2	1 1/2	8 1/2	6 7/8	3 3/4	2 15/16					1 1/4	1 1/4	2 1/4	2 1/2	1/2	3 3/4	3 1/2 X 1/2	3 1/2 X 1/2		
8	2 1/2 X 1/2	13 5/8	11 7/8	3 1/2	4	1 1/2	1 1/2	10 3/4	9 1/8	4 7/8	4 1/16					1 1/4	1 1/4	2 1/4	2 1/2	5/8	4 3/4	4 1/2 X 1/2	4 X 1/2		
12	2 1/2 X 5/8	18 1/4	16 3/8	3 1/2	4	1 1/2	1 1/2	15 1/8	13 1/4	7 1/16	6 1/8					1 1/4	1 1/4	2 1/4	2 1/2	13/16	6 3/4	4 1/2 X 5/8	4 1/2 X 5/8		
16	3 X 3/4	23 1/8	20 3/8	4	4 1/2	1 1/2	1 1/2	19 3/4	17 3/8	9 1/4	8 1/16	1 1/4	1 1/4	1/4	1/4	1 1/2	1 1/2	2 1/2	2 3/4	15/16	9 15/16	5 1/2 X 5/8	5 1/2 X 5/8		
20	3 X 3/4	27 1/2	25	4	4 1/2	1 1/2	1 1/2	24 1/8	21 5/8	11 5/16	10 1/16	1 1/2	1 1/2	3/8	3/8	1 3/4	1 3/4	2 1/4	2 1/2	1	11 1/16	5 1/2 X 5/8	5 1/2 X 5/8		
24	RODS AND CLAMPS NOT ALLOWED																								

NOTE: ALL DIMENSIONS IN INCHES.

CLAMP DETAIL AND DIMENSIONS



Kennedy/Jenks Consultants
Engineers & Scientists

18" SQ. x 6" THICK CONC.
COLLAR REQUIRED OUTSIDE
OF PAVEMENT

GROUND LINE

WORD "WATER" ON COVER

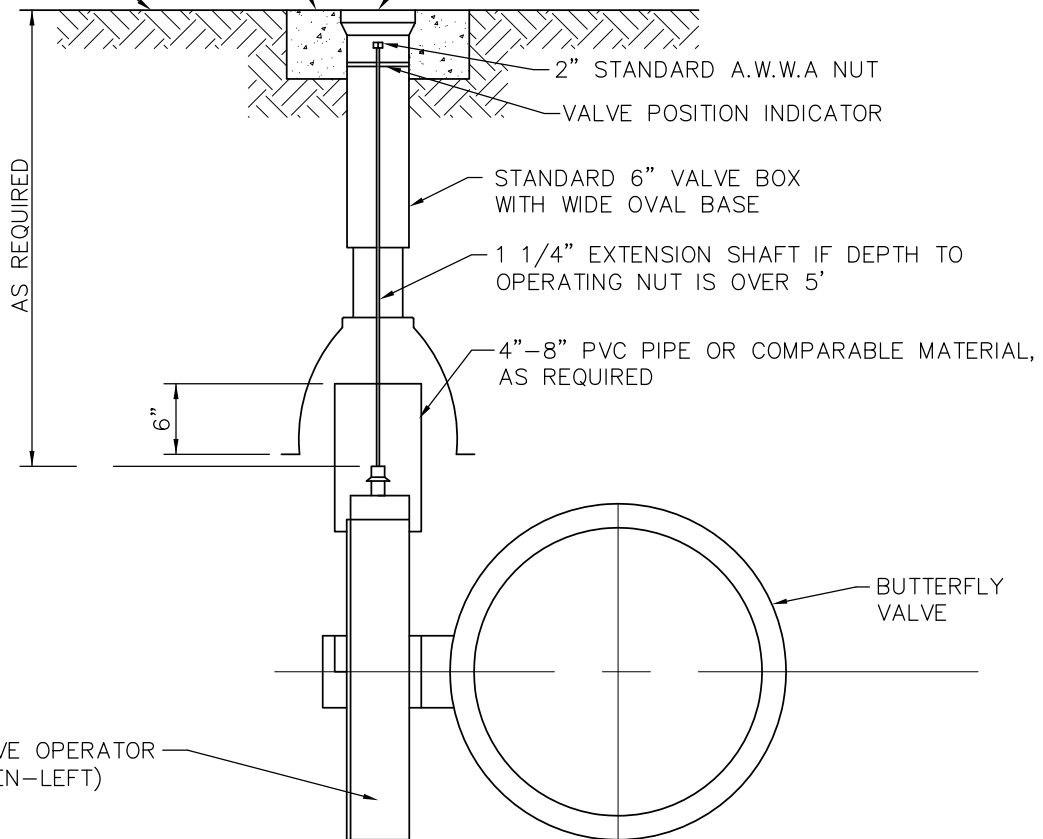

VALVE OPERATOR
(OPEN-LEFT)

BUTTERFLY
VALVE

NOTE:

THE VALVE BOX SHALL NOT BE PLACED DIRECTLY ON THE
PVC PIPE. THIS TYPE OF INSTALLATION IS USED FOR 20"
AND SMALLER VALVES ONLY AND ONLY W/ DISTRICT APPROVAL.
BUTTERFLY VALVE AND OPERATOR SHALL BE POLYETHYLENE WRAPPED.

DIRECT BURY BUTTERFLY VALVE

Castle Pines North
METROPOLITAN DISTRICT

Kennedy/Jenks Consultants
Engineers & Scientists

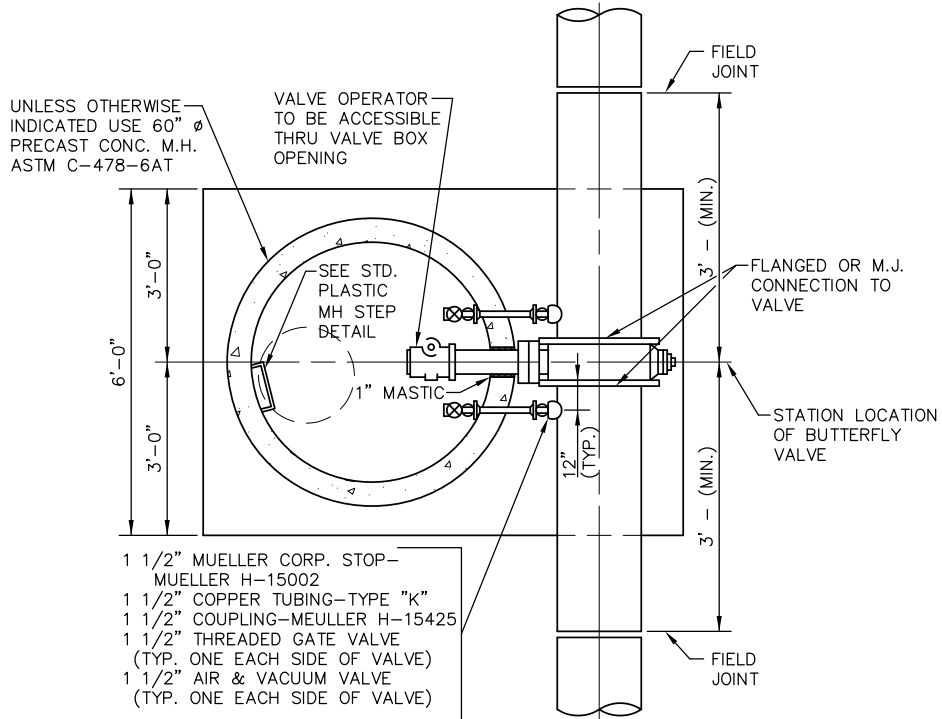

PLAN

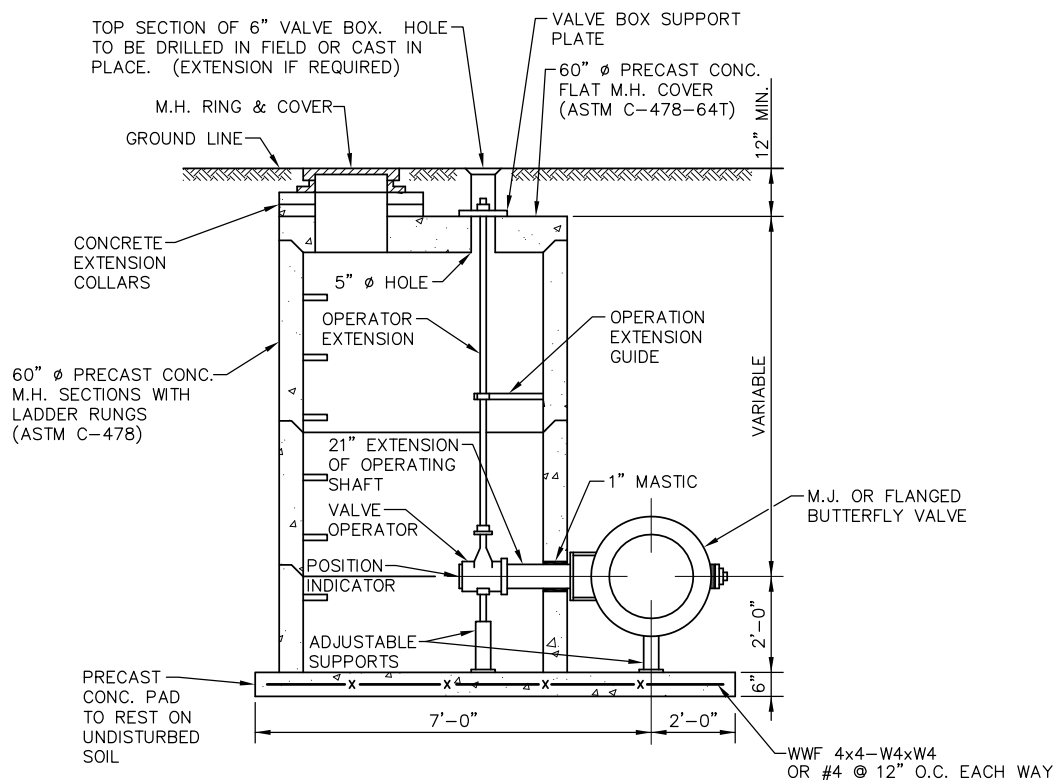

ELEVATION

NOTE: FOR USE WITH VALVES 24" OR LARGER

BUTTERFLY VALVE
AND VAULT ASSEMBLY

Metropolitan District

Kennedy/Jenks Consultants
Engineers & Scientists

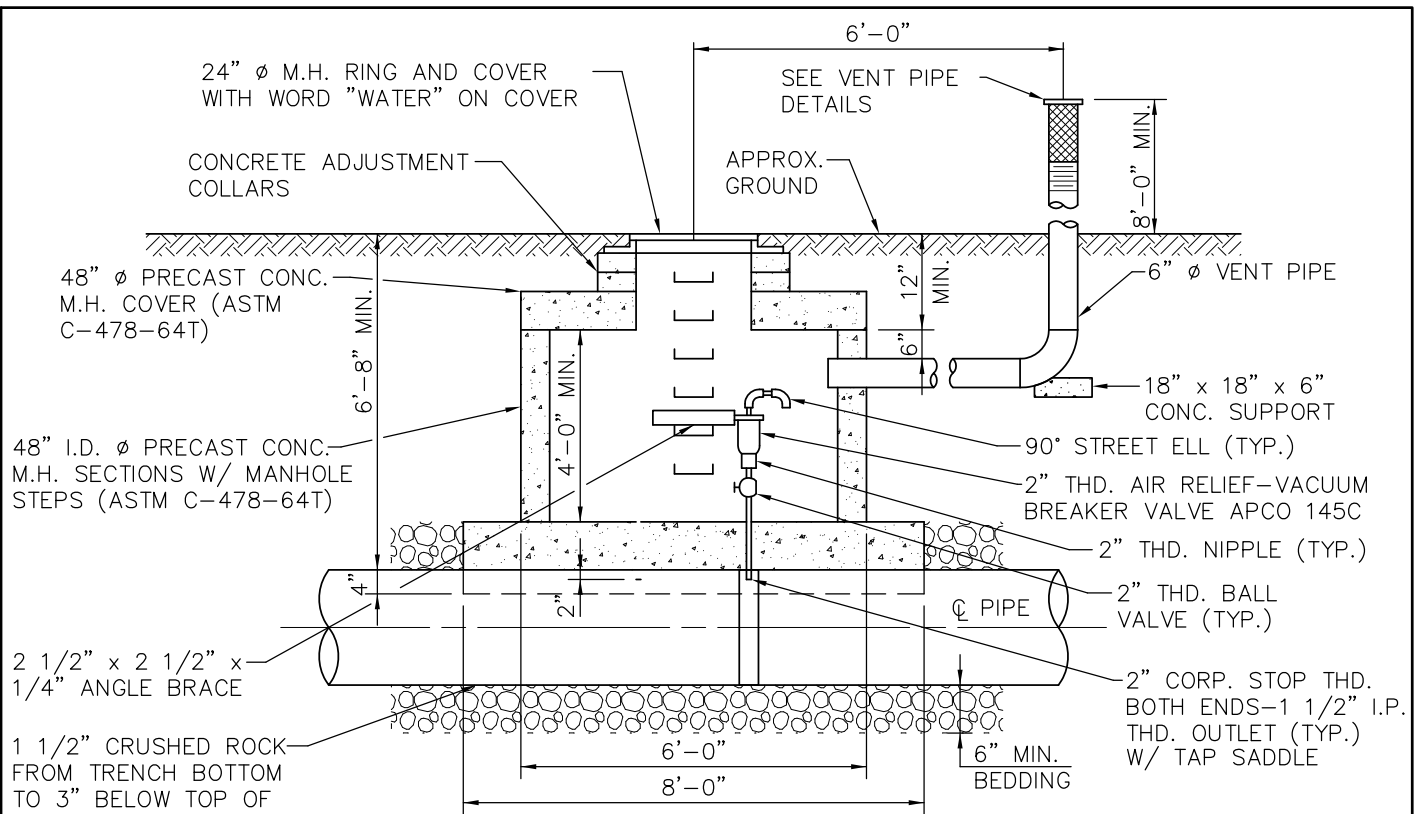

ELEVATION

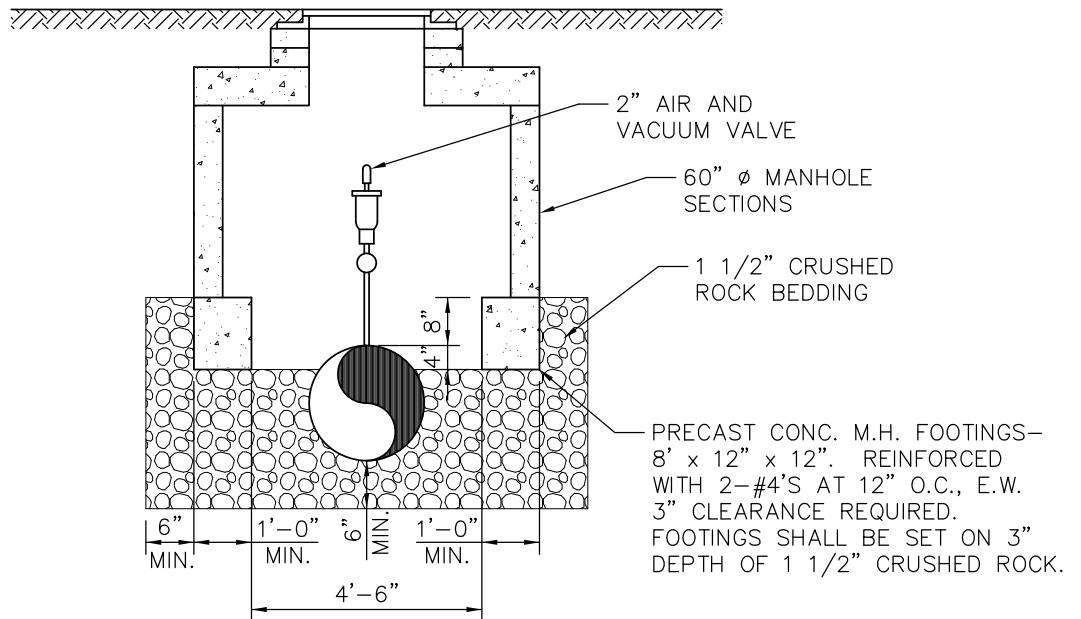

END VIEW

NOTES:

1. PIPE TO BE GRADED SO VALVES ARE AT HIGH POINT IN LINE ON A LEVEL PIPE SECTION WHILE MAINTAINING MINIMUM VAULT DEPTH OF 6'-8". VALVES TO BE PLACED AT CENTER OF A FULL SECTION OF PIPE.
2. DETAIL IS FOR 12-INCH DIAMETER AND SMALLER PIPE. FOR PIPE LARGER THAN 12-INCH: VALVE, VAULT, AND FOOTING SIZES SHALL BE APPROVED BY THE DISTRICT.

AIR RELEASE VALVE AND VAULT

Castle Pines North
METROPOLITAN DISTRICT

Kennedy/Jenks Consultants
Engineers & Scientists

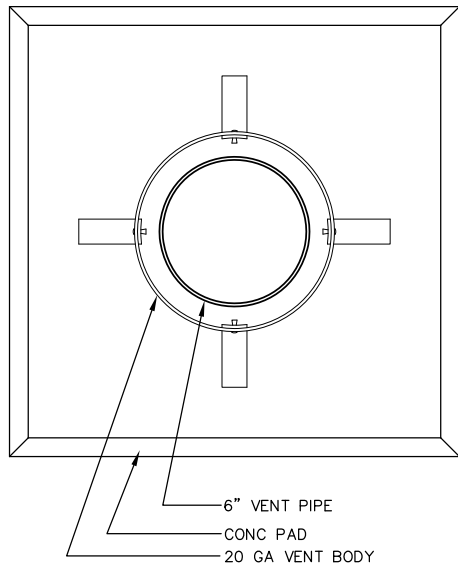

BASE DETAIL

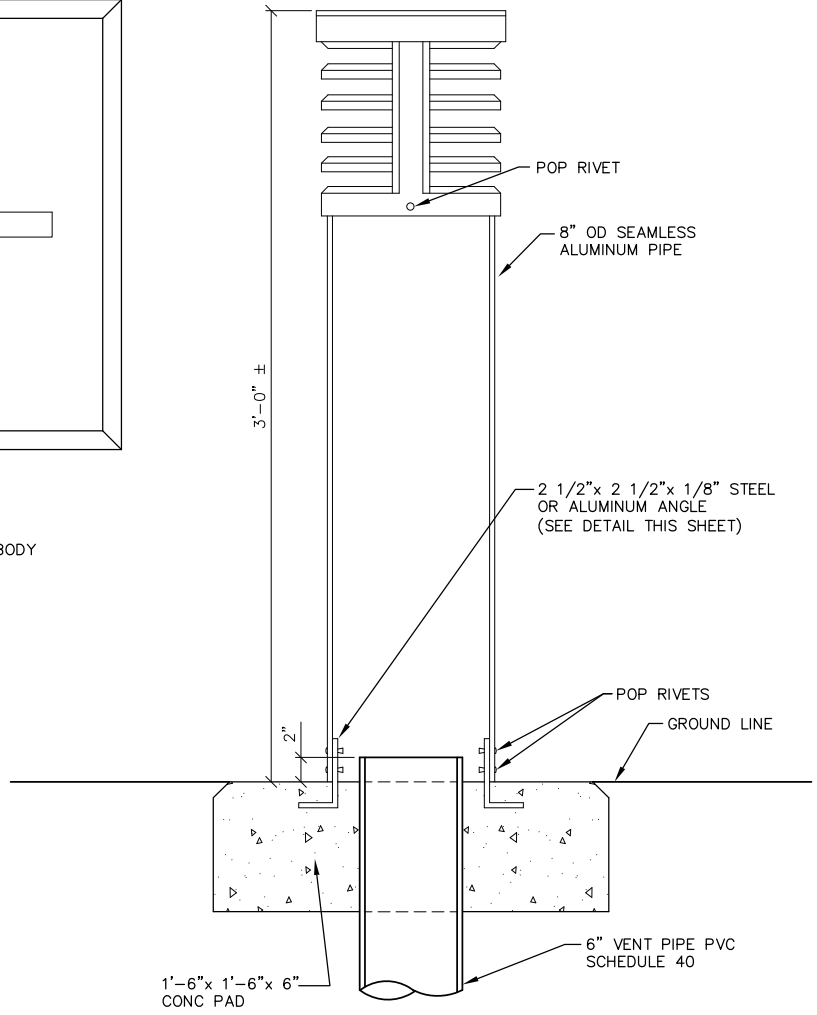

ROUND VENT SCREEN

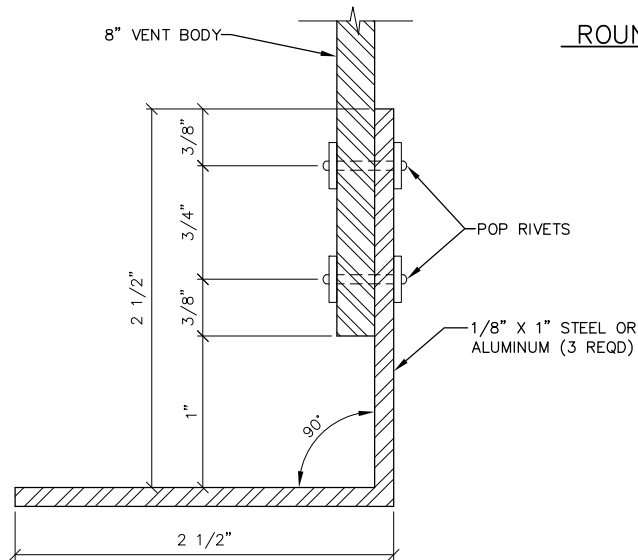

STEEL OR ALUMINUM ANGEL DETAIL

NOTE:
 COLOR SHALL BE OLIVE GREEN
 OR FLAT BLACK TO MATCH
 SURROUNDINGS.

RESIDENTIAL VENT PIPE

Castle Pines North
METROPOLITAN DISTRICT

Kennedy/Jenks Consultants
 Engineers & Scientists

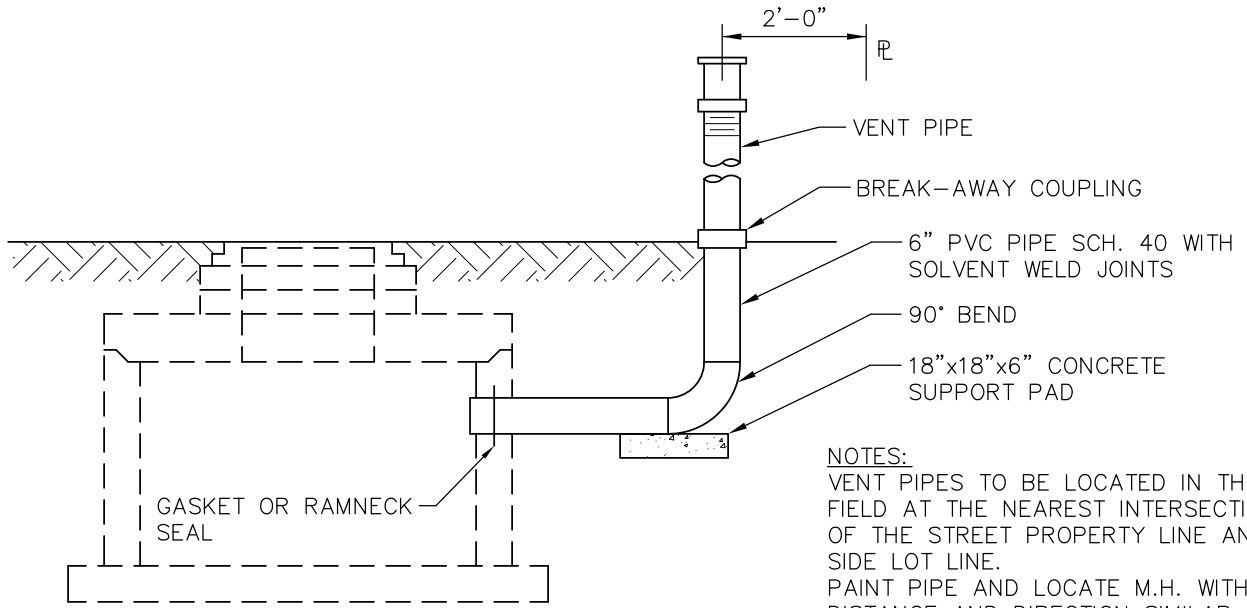

NOTES:
 VENT PIPES TO BE LOCATED IN THE FIELD AT THE NEAREST INTERSECTION OF THE STREET PROPERTY LINE AND SIDE LOT LINE.
 PAINT PIPE AND LOCATE M.H. WITH DISTANCE AND DIRECTION SIMILAR TO MARKER POST.

VENT PIPE INSTALLATION

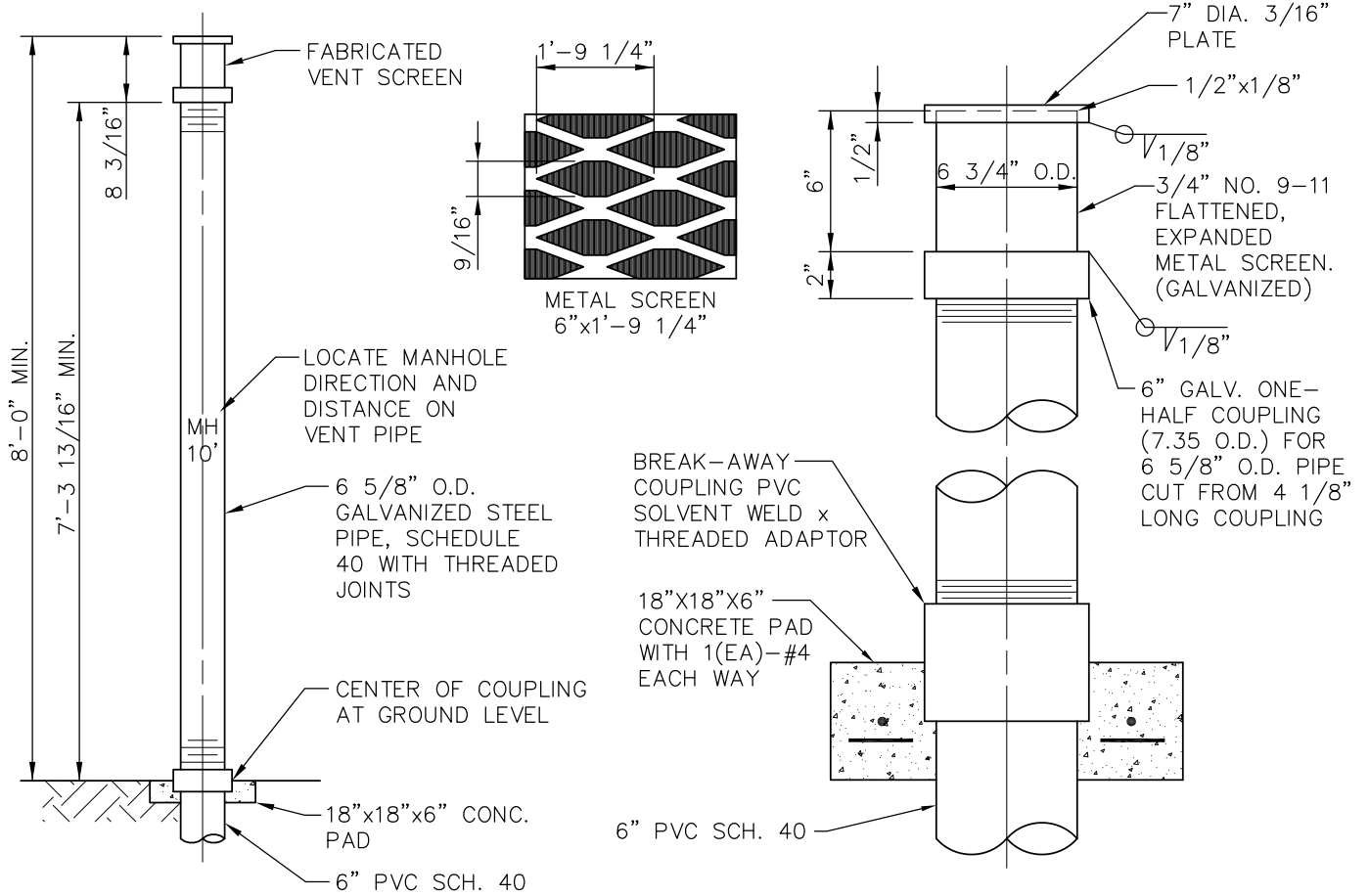

VENT PIPE AND BREAK-AWAY COUPLING DETAILS

PVC VENT PIPE

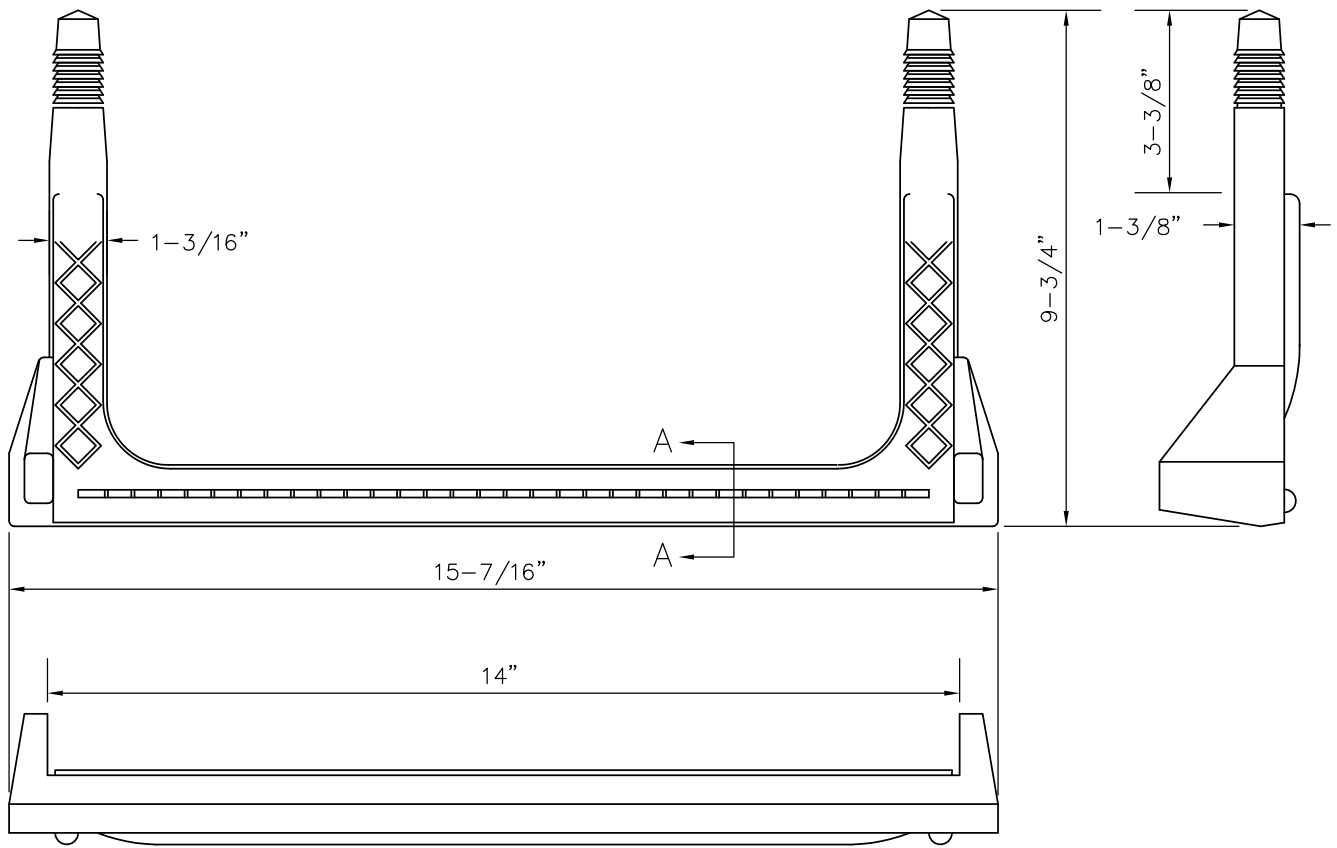

COPOLYMER POLYPROPYLENE PLASTIC

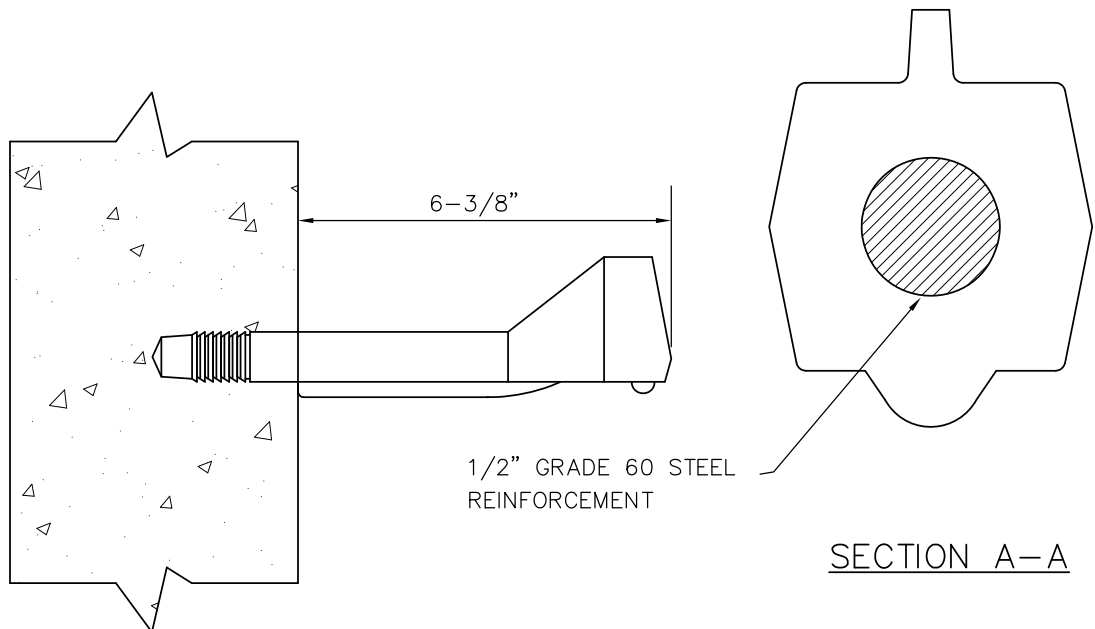

PLASTIC MANHOLE STEP

M *Castle Pines North*
METROPOLITAN DISTRICT

Kennedy/Jenks Consultants
Engineers & Scientists

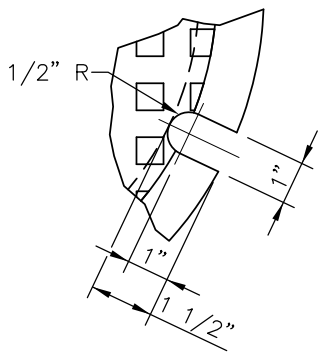
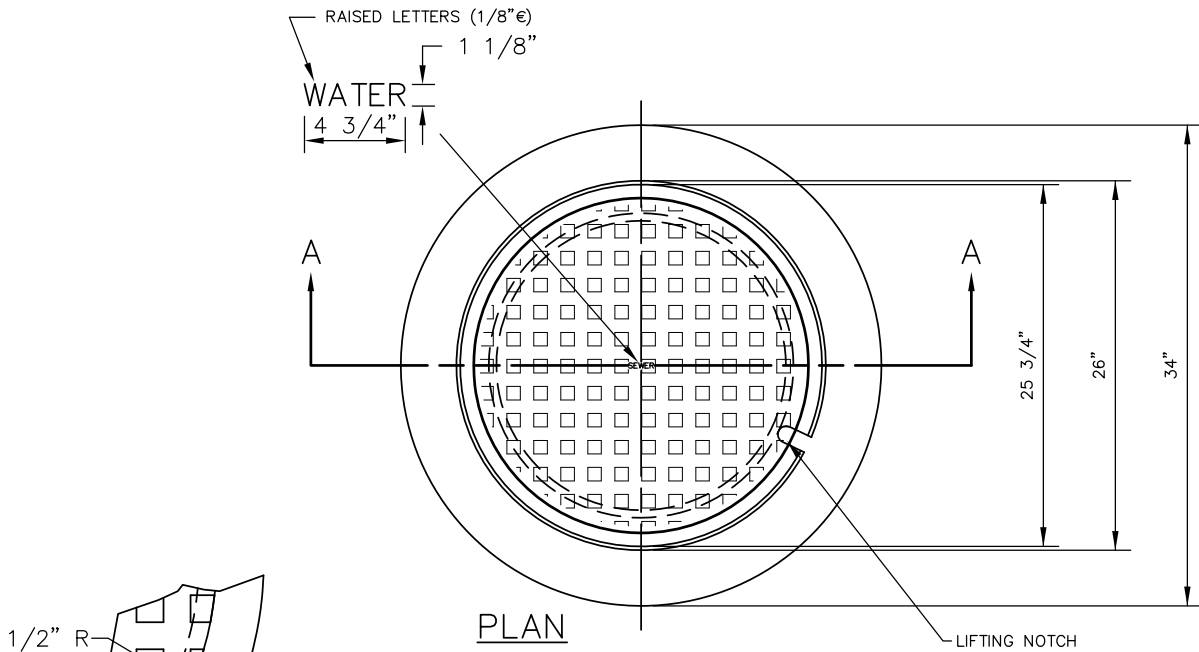

LIFTING NOTCH

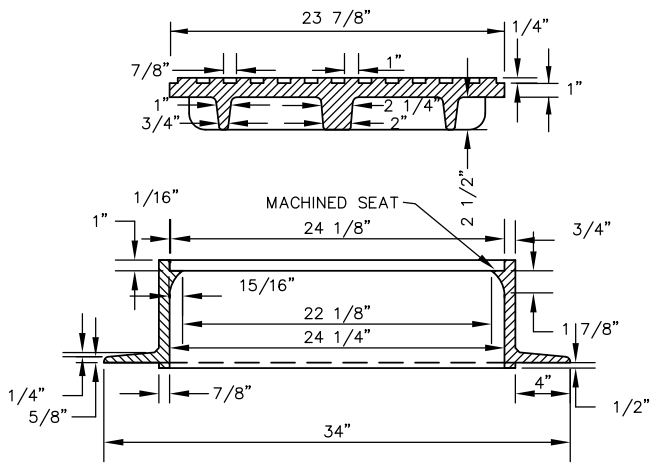

SECTION A-A

NOTES:

1. CASTING SPECIFICATIONS: ASTM A-48 WITH A MINIMUM TENSILE STRENGTH OF 25 KSI (CLASS 25)
2. ALL CASTINGS TO BE DIPPED IN ASPHALT BASE PAINT (OR APPROVED EQUAL)
3. THE DISTRICT MAY REQUIRE A 30" RING & COVER DEPENDING ON THE APPLICATION.
4. CASTINGS SHALL BE AS SPECIFIED BELOW OR EQUAL:

MANUFACTURERS	CAT. #
NEENAH	R-1706
CASTINGS, INC.	MH-400-24 C.I.
HUTCHINSON FDRY. & STL. INC.	MH-400

24" RING AND COVER



Kennedy/Jenks Consultants
Engineers & Scientists

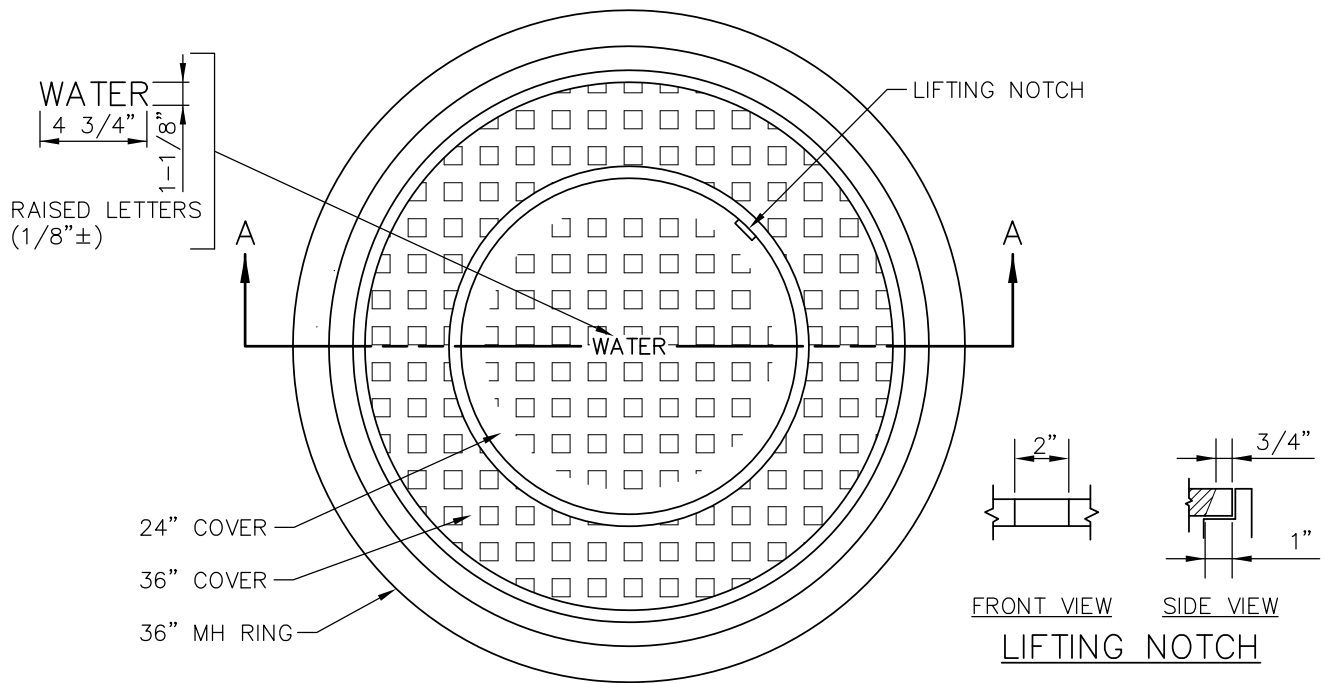

PLAN

NOMINAL WEIGHT

RING=	280#
36" COVER=	250#
24" COVER=	165#
<u>TOTAL=</u>	<u>695#</u>

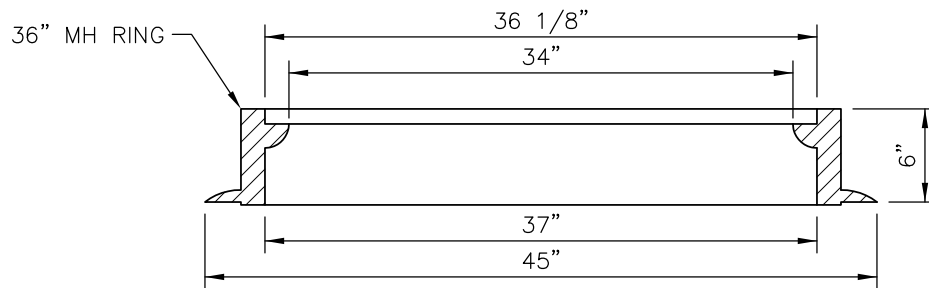
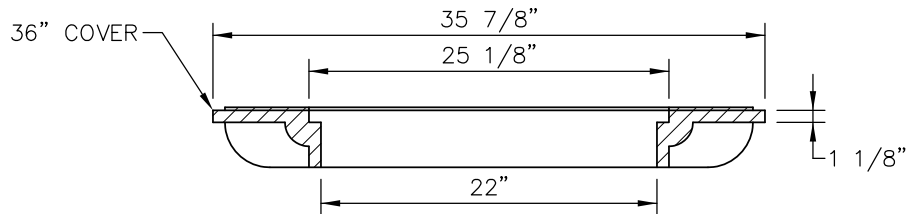
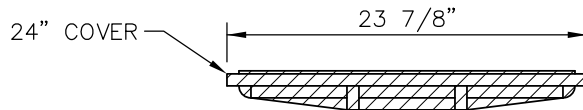

SECTION A-A

NOTES:

1. CASTING SPECIFICATIONS: ASTM A-48 WITH A MINIMUM TENSILE STRENGTH OF 25 KSI (CLASS 25).

2. CASTINGS SHALL BE AS SPECIFIED BELOW OR EQUAL:

<u>MANUFACTURERS</u>	<u>CAT. NO.</u>
CONSTRUCTION CASTINGS	J-1425 (SHOWN)
NEEHAH	R-1740-D2
DEETER	1191

36"x24"
DOUBLE RING AND COVER

Castle Pines North
METROPOLITAN DISTRICT

Kennedy/Jenks Consultants
Engineers & Scientists

PIPE SIZE	RODS NO. AND SIZE	WALL ROD SLEEVES	"A"	"B"
4"	2-3/4" ϕ	1"	3-1/2"	1-7/16"
6"	2-3/4" ϕ	1"	4-3/8"	1-13/16"
8"	2-3/4" ϕ	1"	5-7/16"	2-1/4"
12"	2-3/4" ϕ	1"	8-3/16"	2-3/16"

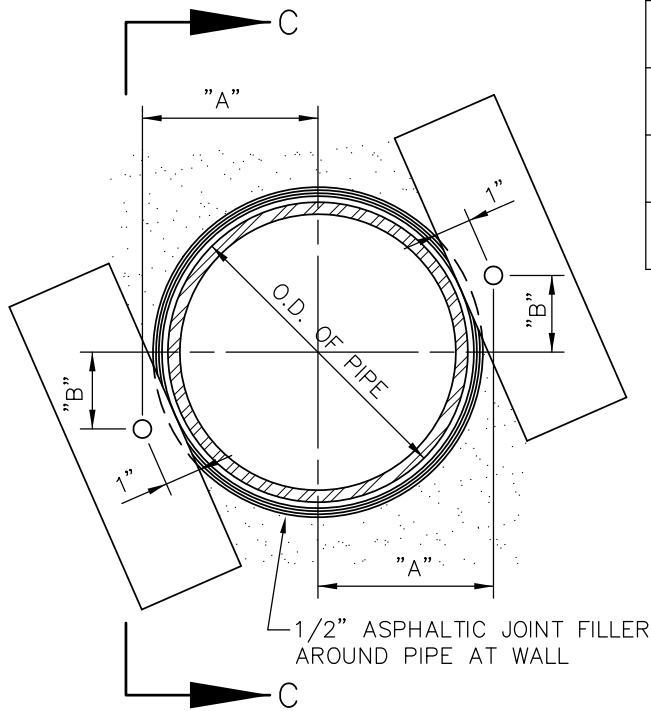

EXTERIOR ELEVATION

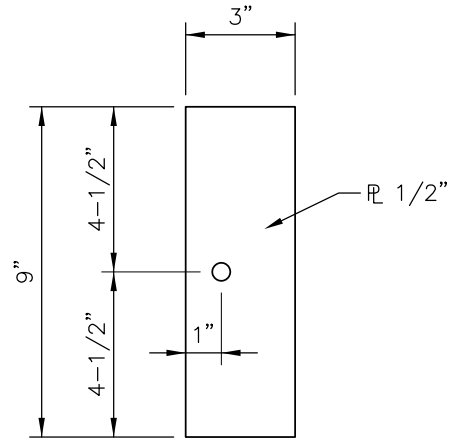

WALL PLATE

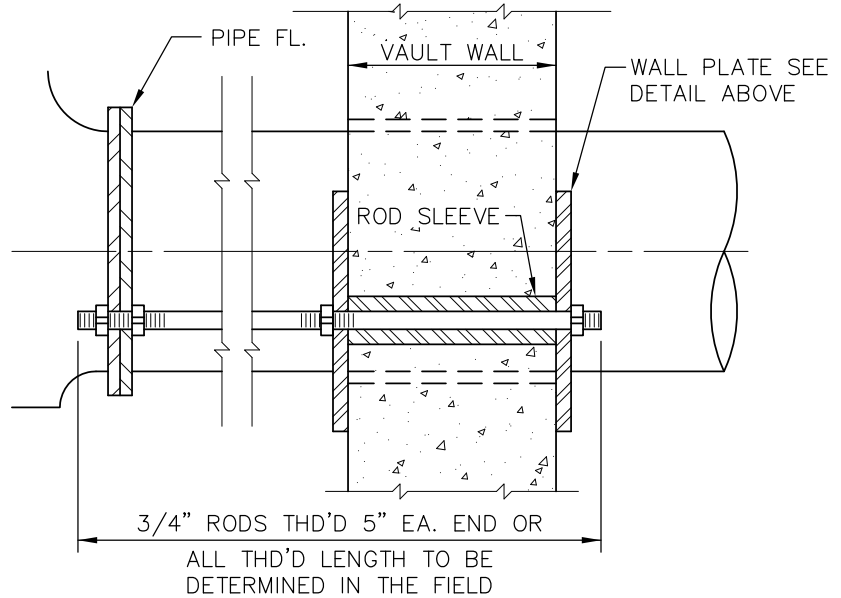

SECTION C-C

WALL CLAMP

Castle Pines North
METROPOLITAN DISTRICT

Kennedy/Jenks Consultants
Engineers & Scientists

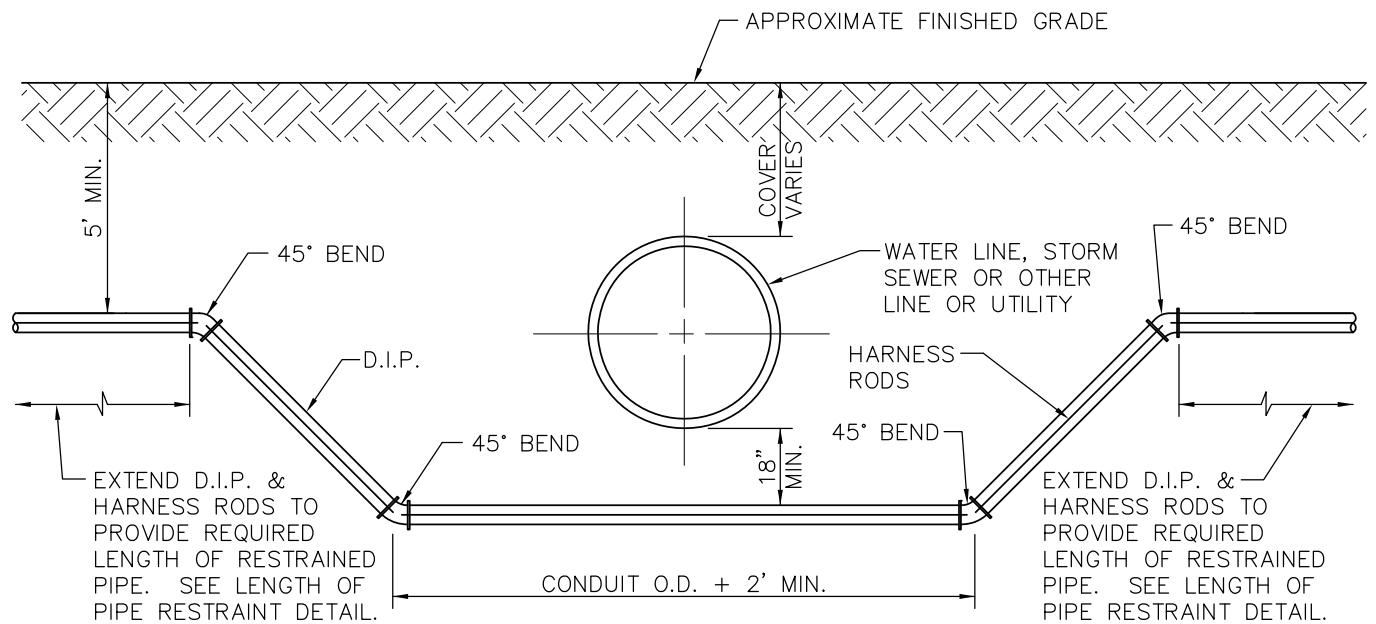

NOTES:

1. LENGTH OF EXTENSION PIPE AND HARNESS RODS SHALL BE IN ACCORDANCE WITH THE DISTRICT SPECIFICATIONS.
2. ALL CONDUIT CROSSINGS SHALL BE POLYETHYLENE WRAPPED DUCTILE IRON PIPE.
3. CATHODIC PROTECTION SHALL BE AS REQUIRED IN ACCORDANCE WITH THE SPECIFICATIONS.
4. DISTRICT-APPROVED MJ RESTRAINT (MEGALUGS) AND JOINT RESTRAINT SYSTEMS MAY BE USED IN PLACE OF HARNESS RODS.

CONDUIT CROSSING

**Castle Pines North
METROPOLITAN DISTRICT**

Kennedy/Jenks Consultants
Engineers & Scientists

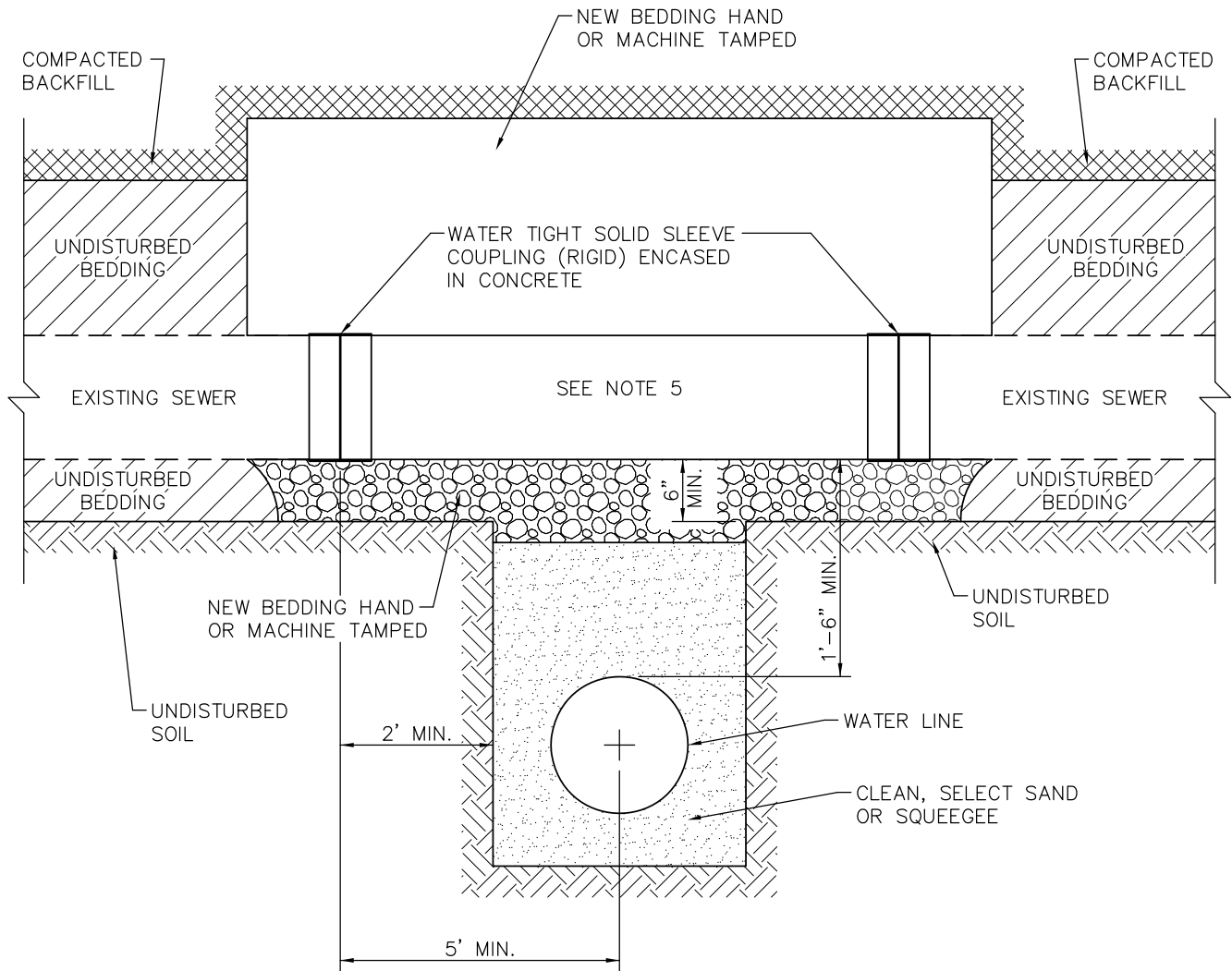

NOTES:

1. THIS STANDARD APPLIES ONLY FOR NON-PRESSURIZED SANITARY SERVICE TAPS AND SANITARY SEWERS EIGHT (8) INCHES AND SMALLER.
2. SANITARY SEWERS MAY NOT BE CUT WITHOUT THE EXPRESSED CONSENT OF THE DISTRICT. A DISTRICT REPRESENTATIVE MUST BE ON SITE DURING CONSTRUCTION. SANITARY SEWER LINE REPAIRS SHALL NOT BE BACKFILLED UNTIL THEY ARE REVIEWED BY THE DISTRICT.
3. THE CONTRACTOR SHALL PROVIDE BYPASS PUMPING UNTIL THE REPAIR IS CONSTRUCTED, REVIEWED, AND APPROVED BY THE DISTRICT.
4. PIPE USED TO REPLACE SECTIONS OF SANITARY SEWER SHALL BE PLACED IN A TRENCH, BEDDED, BACKFILLED AND COMPACTED IN ACCORDANCE WITH THE DISTRICT SPECIFICATIONS.
5. THE MAIN REPAIR SHALL USE PVC PIPE OF A CLASS AT LEAST EQUAL TO THE EXISTING PIPE, BUT IN NO CASE LESS THAN THE FOLLOWING MINIMUM CLASS. FOR LINES 15-INCHES IN DIAMETER OR LESS, ASTM D3034 SDR35, FOR LINES 18-INCHES IN DIAMETER OR LARGER, ASTM F679. THE DISTRICT MAY REQUIRE OTHER MATERIALS AND REPAIR TECHNIQUES ON A CASE BY CASE BASIS. THE NEW PIPE SHALL BE CONNECTED TO THE EXISTING MAIN USING WATER TIGHT SOLID SLEEVE COUPLINGS (RIGID). EACH SOLID SLEEVE SHALL BE ENCASED IN CONCRETE.

**WATER LINE
CROSSING EXISTING SEWER**

**Castle Pines North
METROPOLITAN DISTRICT**

Kennedy/Jenks Consultants
Engineers & Scientists

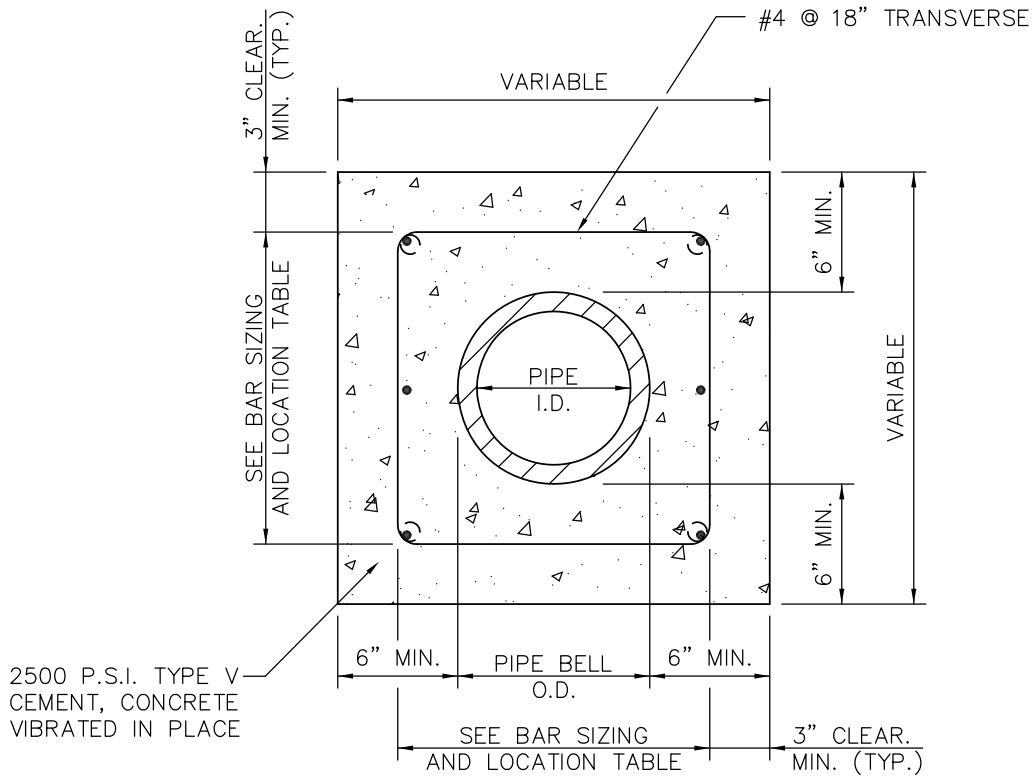

REINFORCEMENT STEEL

PIPE I.D.	LONGITUDINAL BARS – LOCATION		
6 IN.	4–NO. 4 BARS	1 EACH	CORNER
8 IN.	4–NO. 4 BARS	1 EACH	CORNER
10 IN.	8–NO. 4 BARS	3 EACH	SIDE
12 IN.	8–NO. 4 BARS	3 EACH	SIDE
15 IN.	8–NO. 4 BARS	3 EACH	SIDE
18 IN.	8–NO. 4 BARS	3 EACH	SIDE
21 IN.	12–NO. 4 BARS	4 EACH	SIDE
24 IN.	12–NO. 4 BARS	4 EACH	SIDE
27 IN.	12–NO. 4 BARS	4 EACH	SIDE
30 IN.	12–NO. 4 BARS	4 EACH	SIDE
33 IN.	12–NO. 4 BARS	4 EACH	SIDE
36 IN.	16–NO. 4 BARS	5 EACH	SIDE

NOTE:

THE CONCRETE ENCASUREMENT SHALL EXTEND 10LF EACH SIDE OF THE CROSSING WATERLINE.

NOTE:

THE DISTRICT SHALL REVIEW THIS DETAIL FOR USE ON A CASE BY CASE BASIS. SPECIAL ENCASUREMENTS MAY BE REQUIRED AT CREEK CROSSINGS AND CONDUIT CROSSINGS.

**CONCRETE
ENCASEMENT**

**Castle Pines North
METROPOLITAN DISTRICT**

Kennedy/Jenks Consultants
Engineers & Scientists

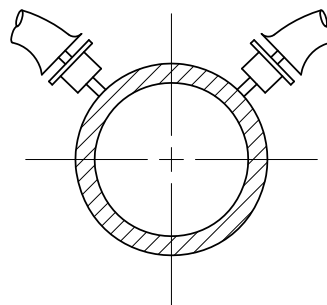
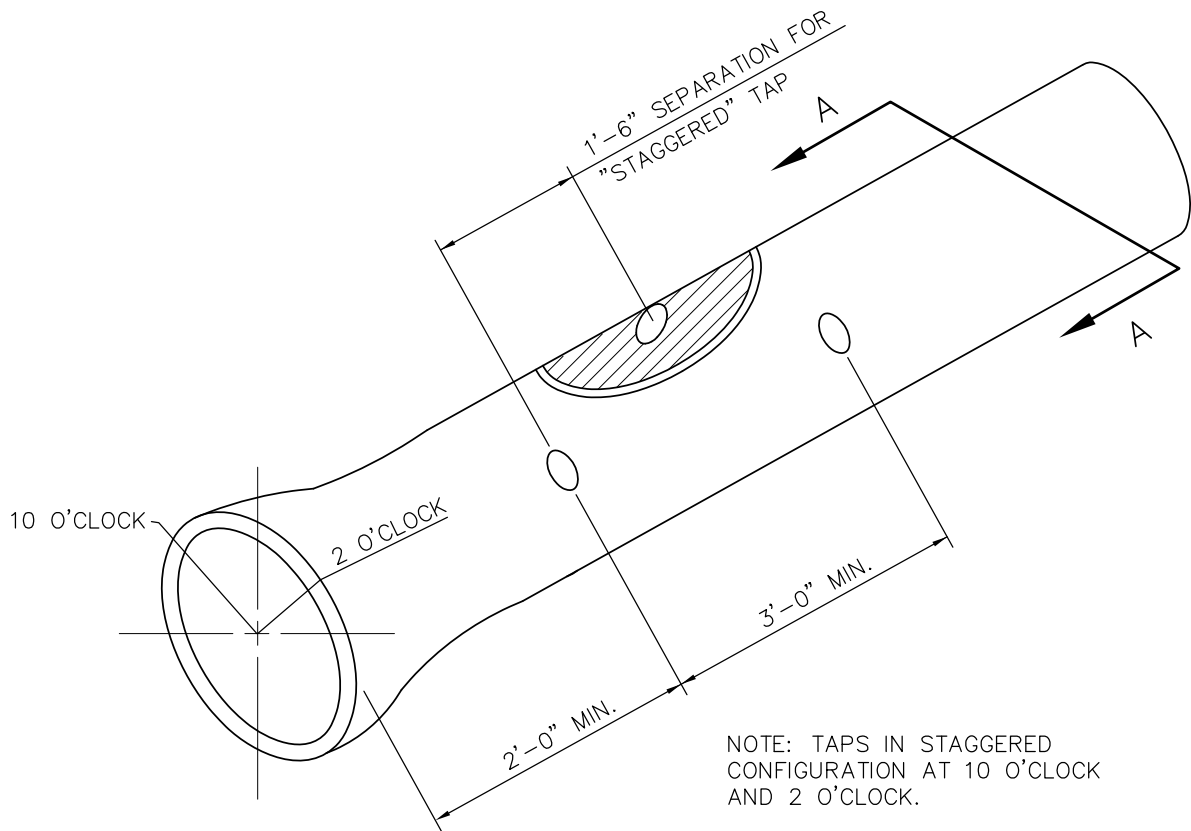

SECTION A-A

WATER

SERVICE TAPS – WATER SERVICE TAPS SHALL BE MADE AT EITHER THE 2 O'CLOCK OR THE 10 O'CLOCK POSITION ON THE CIRCUMFERENCE OF A WATER MAIN. THE MINIMUM DISTANCE BETWEEN A TAP MADE AT THE 2 O'CLOCK POSITION AND THE ONE MADE AT THE 10 O'CLOCK POSITION SHALL BE 18-INCHES MEASURED ALONG THE PIPE. THE MINIMUM DISTANCE BETWEEN SUCCESSIVE TAPS MADE EITHER AT THE 2 O'CLOCK OR THE 10 O'CLOCK POSITION SHALL BE 3- FEET. THE MINIMUM DISTANCE FROM EITHER THE BELL OR THE SPIGOT END OF A PIPE TO A TAP SHALL BE 2- FEET. A MAXIMUM OF 4 WATER SERVICE TAPS SHALL BE ALLOWED PER LENGTH OF PIPE.

DOMESTIC WATER TAPPING

M *Castle Pines North*
METROPOLITAN DISTRICT

Kennedy/Jenks Consultants
Engineers & Scientists

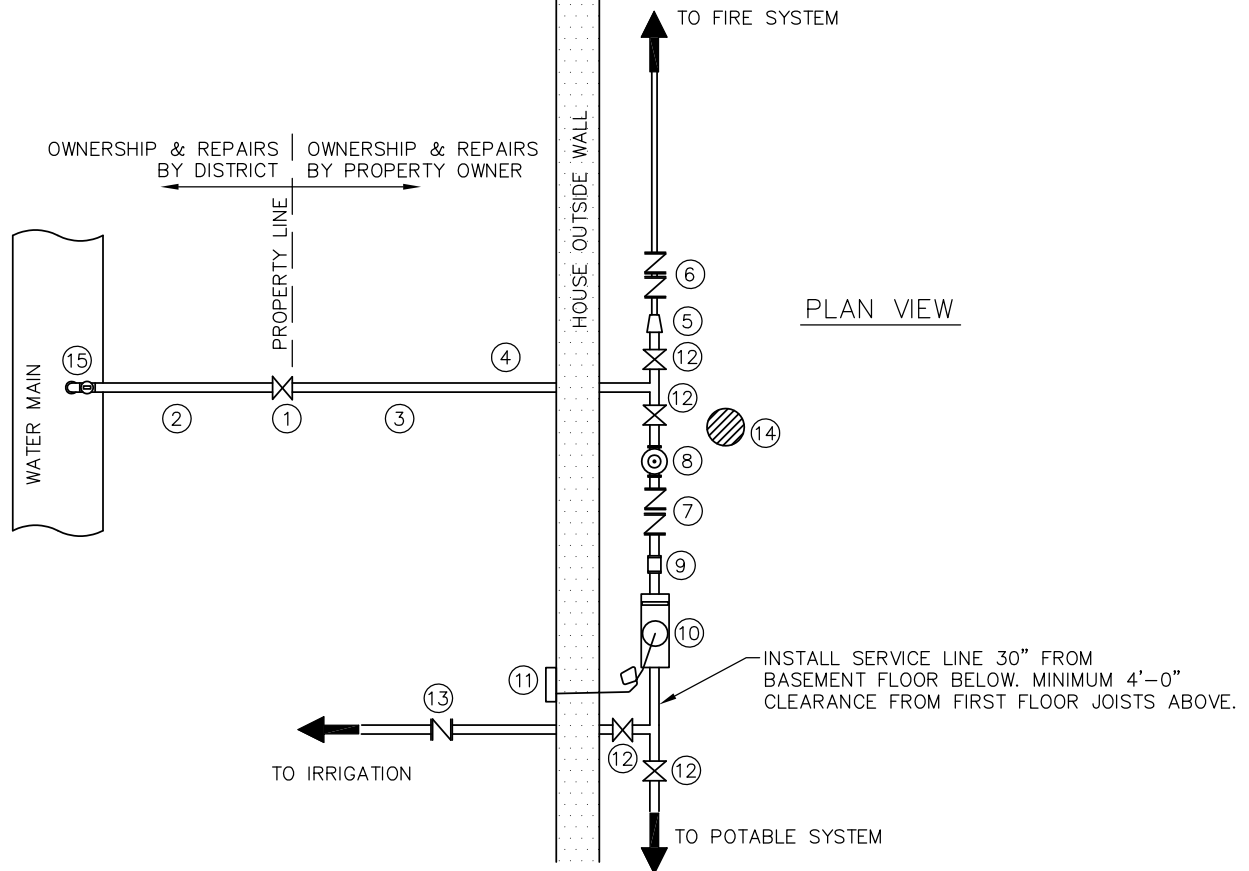

- ① PROPERTY LINE SHUT-OFF VALVE
MULLER 15000 (MIN 3/4")*
FORD B-22-444 (MIN 3/4")*
BOX-TYLER 4 1/4" DROP LID #6870
 - ② DISTRICT BEARS RESPONSIBILITY FOR SERVICE LINE FROM MAIN TO OUTLET OF PROPERTY LINE SHUT-OFF VALVE.
 - ③ PROPERTY OWNER BEARS RESPONSIBILITY FOR SERVICE LINE FROM OUTLET SIDE OF PROPERTY LINE SHUT-OFF VALVE TO BUILDING.
 - ④ TYPE "K" COPPER BUILDING SERVICE LINE (MIN 3/4")*
 - ⑤ BUILDING WATER LINE REDUCER
 - ⑥ FIRE PROTECTION SPRINKLER SYSTEM BACKFLOW PREVENTOR FEBCO 825Y-BV REDUCED PRESSURE PRINCIPLE ASSEMBLY. A DOUBLE CHECK ASSEMBLY MAY BE USED WITH PRIOR APPROVAL BY THE DISTRICT AND THE FIRE PROTECTION DISTRICT FOR LOW RISK APPLICATIONS.
 - ⑦ BUILDING WATER SERVICE LINE BACKFLOW PREVENTOR FEBCO 805Y-BV DOUBLE CHECK.
 - ⑧ BUILDING WATER SERVICE LINE PRESSURE REDUCER
 - ⑨ PIPE COUPLER
 - ⑩ WATER METER AND REMOTE FURNISHED BY DISTRICT. SIZE OF TAP AND METER TO BE APPROVED BY DISTRICT.
 - ⑪ WATER METER REMOTE READOUT LOCATED AT FRONT GARAGE DOOR (LOCATION NOT MORE THAN 100 FEET FROM METER)
 - ⑫ GLOBE SHUT-OFF VALVE
 - ⑬ IRRIGATION SPRINKLER SYSTEM PRESSURE VACUUM BREAKER FEBCO 765-BV
 - ⑭ FLOOR DRAIN
 - ⑮ CONNECTION TO WATER MAIN – CORPORATION STOP FOR USE WITH DIP. DOUBLE BRONZE-STRAP TAPPING SADDLE WITH AWWA STANDARD TAPER THREADS AND INSULATOR. SIZE TO MATCH SERVICE LINE FROM MAIN TO METER.
- NOTES:
1. THE PROPERTY OWNER MUST PROVIDE A PROPERTY LINE SHUT-OFF VALVE THAT IS EASILY ACCESSIBLE TO DISTRICT PERSONNEL. SHUT-OFF VALVES MAY BE INSTALLED INSIDE THE BUILDING ONLY WITH PRIOR APPROVAL BY THE DISTRICT. WHERE THE SHUT-OFF VALVE IS INSTALLED INSIDE THE BUILDING, THE VALVE MUST BE A LOCKING-TYPE VALVE APPROVED BY THE DISTRICT, AND THE PROPERTY OWNER MUST PROVIDE DISTRICT PERSONNEL WITH COMPLETE ACCESS TO THE VALVE AT ALL TIMES.
 2. ALL TAPS, SERVICE LINES, FITTINGS, AND METER SETTINGS (INCLUDING INTERNAL SETTINGS) MUST BE INSPECTED BY THE CASTLE PINES NORTH METROPOLITAN DISTRICT. IT IS THE DEVELOPER'S RESPONSIBILITY TO CONTACT THE DISTRICT AT (303) 688-8550.
 3. ALL PIPE, FITTINGS, AND APPURTENANCES MUST MEET LEAD-FREE REQUIREMENTS.

**DOMESTIC WATER SERVICE
(INSIDE SETTING)**

**Castle Pines North
METROPOLITAN DISTRICT**

Kennedy/Jenks Consultants
Engineers & Scientists

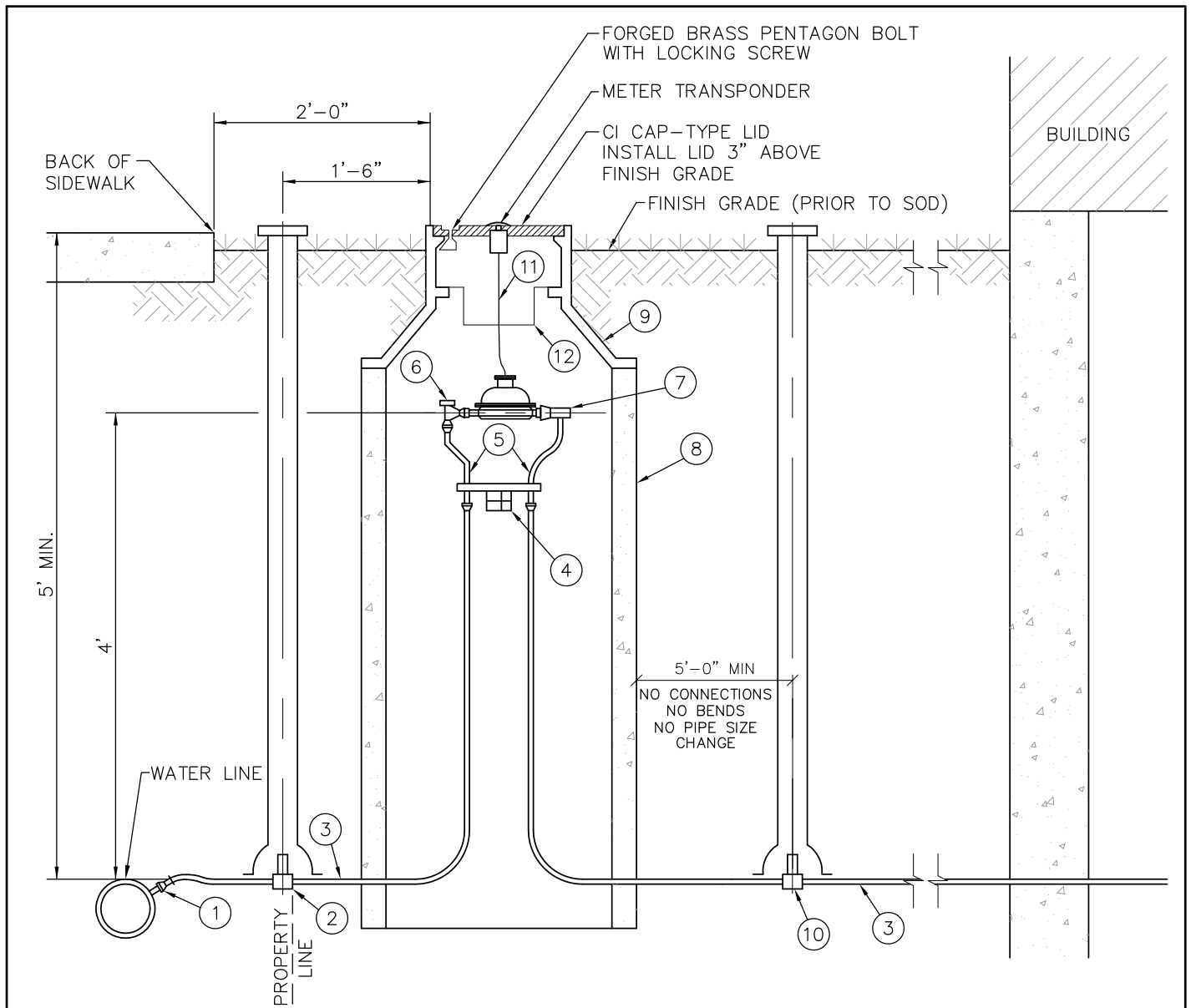

OWNERSHIP & REPAIRS BY DISTRICT | OWNERSHIP & REPAIRS BY PROPERTY OWNER

DESCRIPTION:

1. CORPORATION STOP WITH INSULATING COUPLING
2. PROPERTY LINE CURB STOP AND BOX
3. SERVICE LINE—COPPER TUBING TYPE 'K' ONLY
4. METER YOKE BRACE
5. METER YOKE—FORD 80 SERIES WITH LOCKING SHUT-OFF VALVE AND CHECK VALVE. FORD COPPERSETTER FOR COPPER SERVICE WITH TUBE NUTS AND WIRING LOCKS. CONTACT THE DISTRICT FOR METER LENGTH (688-8550).
6. LOCKING SHUT-OFF VALVE
7. CHECK VALVE
8. PRECAST CONC METER PIT—24" I.D. x 28" O.D. x 4'-6"
9. METER PIT DOME—CASINGS, INC. CI-70, W32, OR APPROVED EQUAL. LID SHALL BE CAST IRON.
10. STOP & WASTE VALVE AND BOX (IRRIGATION ONLY) INSTALL 1/4 CU YD OF 1-1/2" CRUSHED ROCK WITH MIRAFI FABRIC FOR DRAIN.
11. TRANSPONDER SIGNAL WIRE
12. PLASTIC FROST LID WITH NOTCH FOR TRANSPONDER WIRE

NOTES:

1. THIS DETAIL TO BE USED FOR IRRIGATION SERVICES. IT MAY BE USED FOR MULTI-FAMILY SERVICES ONLY WITH PRIOR APPROVAL FROM THE DISTRICT. NOT FOR USE ON SINGLE FAMILY HOMES.
2. SERVICE LINE MUST HAVE MIN. 5' COVER.
3. THERE SHALL NOT BE ANY CONNECTIONS MADE WITHIN 5'-0" OF THE METER.
4. ONLY CONCRETE METER PITS SHALL BE ACCEPTED.
5. ALL TAPS, SERVICE LINES, FITTINGS, AND METER SETTINGS MUST BE INSPECTED BY THE CASTLE PINES NORTH METROPOLITAN DISTRICT. IT IS THE DEVELOPER'S RESPONSIBILITY TO CONTACT THE DISTRICT AT (303) 688-8550.

**WATER SERVICE
(3/4" AND 1" OUTSIDE SETTING)**

**Castle Pines North
METROPOLITAN DISTRICT**

Kennedy/Jenks Consultants
Engineers & Scientists

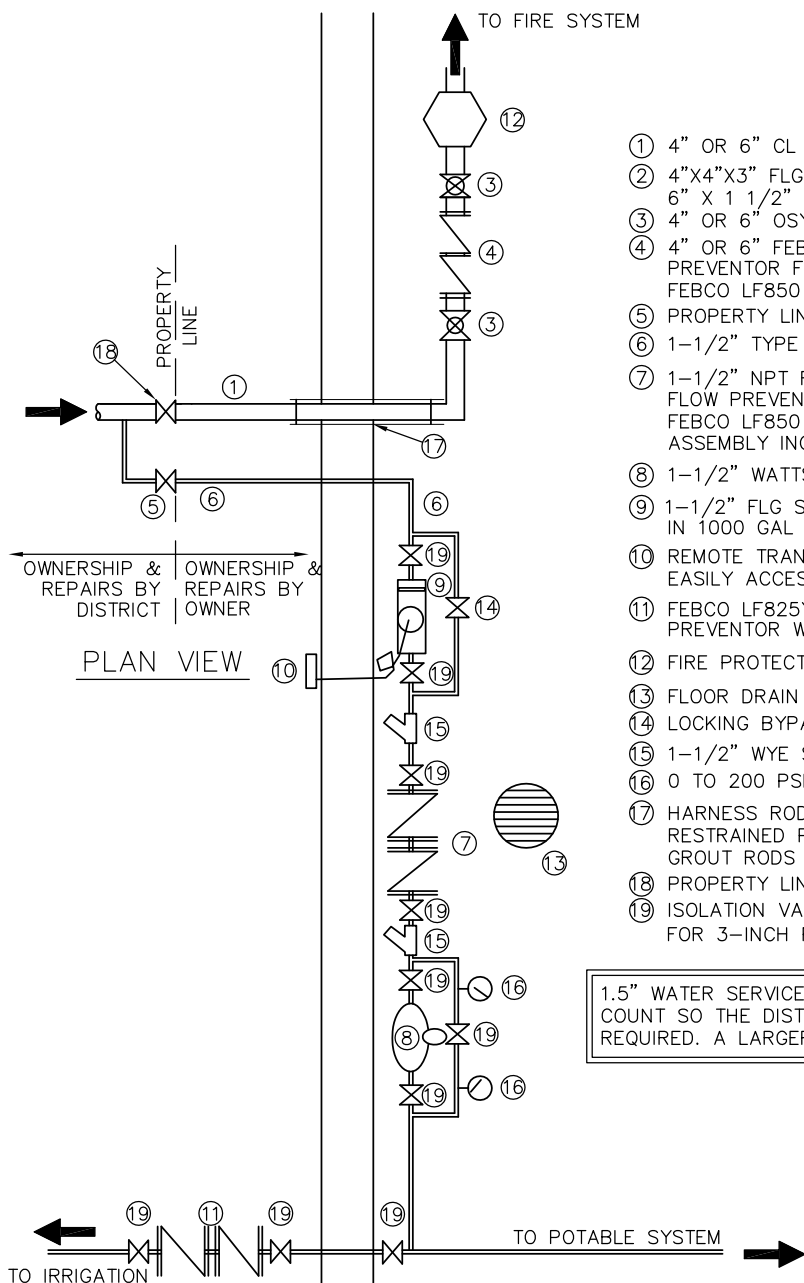

- ① 4" OR 6" CL 50 DIP SERVICE/ FIRELINE
- ② 4"x4"x3" FLG TEE W/ 1-1/2" NPT REDUCING FLG OR 6" X 1 1/2" FORD FS202 IP6 SADDLE
- ③ 4" OR 6" OSY RESILIENT WEDGE GATE VALVE
- ④ 4" OR 6" FEBCO LF880 OSY REDUCED PRESSURE BACKFLOW PREVENTOR FOR HIGH HAZARD CONDITIONS OR A FEBCO LF850 OSY DOUBLE CHECK VALVE FOR LOW HAZARD
- ⑤ PROPERTY LINE 1-1/2" CURB STOP W/ 6" VALVE BOX
- ⑥ 1-1/2" TYPE K COPPER SERVICE LINE
- ⑦ 1-1/2" NPT FEBCO LF825YA W/AGD-Y REDUCED PRESSURE BACKFLOW PREVENTOR FOR HIGH HAZARD CONDITIONS OR A FEBCO LF850 DOUBLE CHECK VALVE FOR LOW HAZARD ASSEMBLY INCLUDES ISOLATION VALVES
- ⑧ 1-1/2" WATTS LF223 PRESSURE REDUCING VALVE
- ⑨ 1-1/2" FLG SENSUS "SR" WATER METER WITH TOUCH READ SYSTEM IN 1000 GAL INCREMENTS (MUST MEET LEAD-FREE REQUIREMENTS)
- ⑩ REMOTE TRANSPONDER ATTACHED TO EXTERIOR OF BUILDING IN EASILY ACCESSIBLE AREA NO MORE THAN 100' FROM METER
- ⑪ FEBCO LF825YA REDUCED PRESSURE BACKFLOW PREVENTOR WITH ISOLATION VALVES FOR IRRIGATION SYSTEM
- ⑫ FIRE PROTECTION SYSTEM (BY OTHERS)
- ⑬ FLOOR DRAIN
- ⑭ LOCKING BYPASS VALVE
- ⑮ 1-1/2" WYE STRAINER
- ⑯ 0 TO 200 PSI PRESSURE GAGE
- ⑰ HARNESS RODS TO PROVIDE REQUIRED LENGTH OF RESTRAINED PIPE. SEE LENGTH OF RESTRAINED PIPE DETAIL. GROUT RODS IN WALL.
- ⑱ PROPERTY LINE MJ GATE VALVE
- ⑲ ISOLATION VALVE. FOR 2-INCH PIPE AND SMALLER USE BALL VALVE FOR 3-INCH PIPE AND LARGER, USE GATE VALVE.

1.5" WATER SERVICE SHOWN. OWNER MUST PROVIDE WATER FIXTURE COUNT SO THE DISTRICT CAN DETERMINE THE MINIMUM SERVICE SIZE REQUIRED. A LARGER SERVICE MAY BE REQUIRED.

NOTES:

- 1. DISTRICT BEARS RESPONSIBILITY FOR FIRE LINE AND SERVICE LINE FROM MAIN TO OUTLET OF PROPERTY LINE SHUT-OFF VALVE.
- 2. PROPERTY OWNER BEARS RESPONSIBILITY FOR FIRE LINE AND SERVICE LINE FROM OUTLET OF PROPERTY LINE SHUT-OFF VALVE TO BUILDING.
- 3. THE BACKFLOW ASSEMBLIES SHALL BE CERTIFIED BY AN INDEPENDENT INSPECTOR AFTER INSTALLATION. IT IS THE CUSTOMERS RESPONSIBILITY TO HAVE THE BACKFLOW SYSTEM RE-CERTIFIED ANNUALLY AND THE RESULTS BE PROVIDED TO THE DISTRICT OFFICE.
- 4. THE DISTRICT MUST APPROVE ALL BACKFLOW ASSEMBLIES.
- 5. VIEW SHOWN IS PLAN VIEW. IF VERTICAL INSTALLATION IS REQUIRED, ALL COMPONENTS MUST BE REVIEWED BY THE DISTRICT
- 6. THE PROPERTY OWNER MUST PROVIDE A PROPERTY LINE SHUT-OFF VALVE THAT IS EASILY ACCESSIBLE TO DISTRICT PERSONNEL. SHUT-OFF VALVES MAY BE INSTALLED INSIDE THE BUILDING ONLY WITH PRIOR APPROVAL BY THE DISTRICT. WHERE THE SHUT-OFF VALVE IS INSTALLED INSIDE THE BUILDING, THE VALVE MUST BE A LOCKING-TYPE VALVE APPROVED BY THE DISTRICT, AND THE PROPERTY OWNER MUST PROVIDE DISTRICT PERSONNEL WITH COMPLETE ACCESS TO THE VALVE AT ALL TIMES.
- 7. ALL TAPS, SERVICE LINES, FITTINGS, AND METER SETTINGS (INCLUDING INTERNAL SETTINGS) MUST BE INSPECTED BY THE CASTLE PINES NORTH METROPOLITAN DISTRICT. IT IS THE DEVELOPER'S RESPONSIBILITY TO CONTACT THE DISTRICT AT (303) 688-8550.
- 8. ALL PIPE, FITTINGS, AND APPURTENANCES MUST MEET LEAD-FREE REQUIREMENTS.

COMMERCIAL WATER SERVICE



Kennedy/Jenks Consultants
Engineers & Scientists

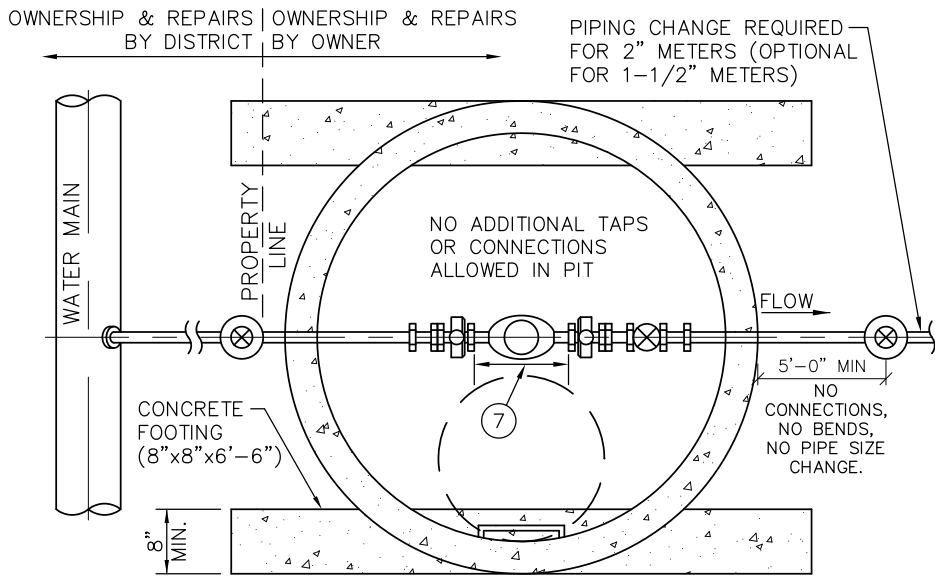

PLAN

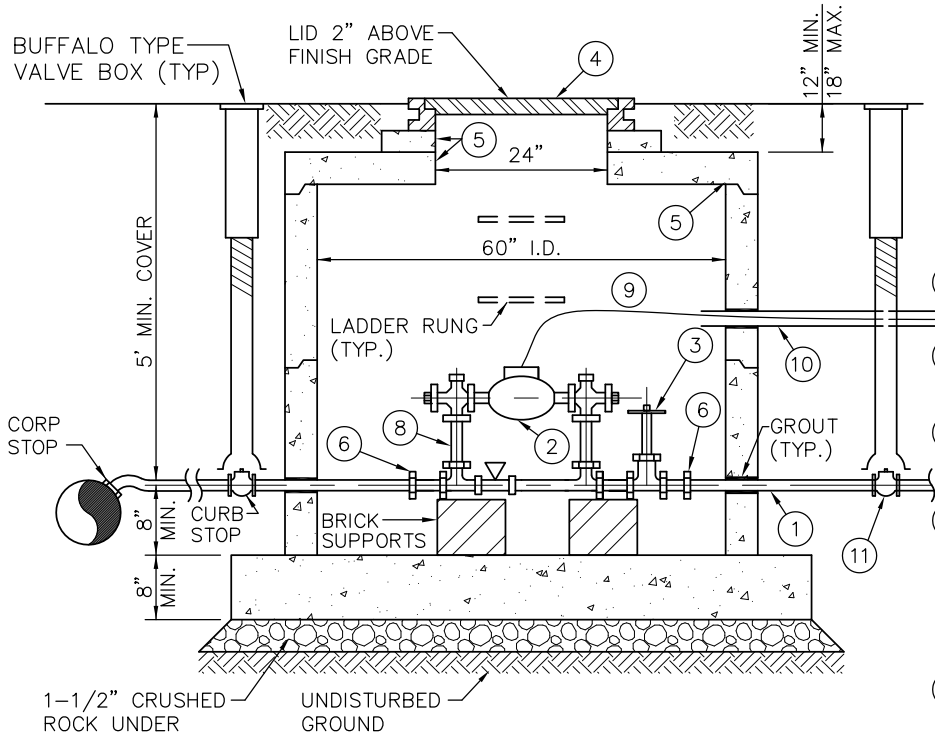

ELEVATION

- ⑨ SIGNAL WIRE TO REMOTE TRANSPONDER
- ⑩ PVC CONDUIT TO REMOTE TRANSPONDER LOCATION APPROVED BY DISTRICT
- ⑪ STOP & WASTE VALVE AND BOX (IRRIGATION ONLY). INSTALL 1/4 CU YD OF 1/2" CRUSHED ROCK AND MIRIFI FABRIC UNDER VALVE.

NOTES:

1. WATER METER FURNISHED BY DISTRICT. INSTALL TO BE DONE BY CONTRACTOR.
2. SERVICE LINE MUST HAVE A MINIMUM COVER OF 5 FEET.
3. CONTRACTOR SHALL INSTALL DISTRICT-APPROVED BACKFLOW PREVENTOR DOWNSTREAM OF THE STOP & WASTE VALVE.
4. DISTRICT PERSONNEL SHALL INSPECT THE SERVICE LINE FROM THE MAIN TO THE OUTLET SIDE OF THE BACKFLOW PREVENTOR PRIOR TO BACKFILLING. CALL 303-688-8550 FOR INSPECTION.
5. CONCRETE SHALL NOT BE LAID IN FLOOR OF METER PIT.
6. FOOTINGS ARE TO BE INSTALLED UNDER METER PIT.
7. FIELD SOLDERED JOINTS OR PLASTIC PIPE ARE NOT ALLOWED IN METER PIT.
8. NO FITTINGS OR PIPE SIZE CHANGE ALLOWED WITHIN 5 FT OF THE METER.
9. THIS DETAIL TO BE USED FOR IRRIGATION SERVICES. IT MAY BE USED FOR COMMERCIAL AND MULTI-FAMILY SERVICES ONLY WITH PRIOR APPROVAL FROM THE DISTRICT.

MATERIALS:

- ① WATER SERVICE LINE - COPPER TUBING (TYPE K), 5 FT MIN COVER
- ② WATER METER - FURNISH WIRING FOR TRANSPONDER PER DISTR STANDARDS.
- ③ CHECK VALVE - CLASS 125 CONNECTED WITH "LOK-PAX" OR COMPRESSION COUPLING.
- ④ RING AND COVER - 24" NEENAH R - 1706-1 WEIGHT 230 LBS. OR EQUAL, "WATER" CAST INTO COVER. IF IN PAVEMENT, LID SHOULD BE ABLE TO WITHSTAND HS-20 TRAFFIC LOADING.
- ⑤ PRECAST 60" I.D. MANHOLE - ASTM C-478 WITH MANHOLE STEPS, OFFSET FLAT TOP, AND CONCRETE ADJUSTMENT RINGS.
- ⑥ COPPER TO BRASS FITTINGS.
- ⑦ CALL 688-8550 FOR DIMENSIONS.
- ⑧ FORD "CUSTOM SETTER" METER SET WITH FLANGED BALL VALVE, ANGLE, CHECK VALVE AND LOCKABLE BYPASS. 1 1/2" MODEL NO. VBH76-12B-X LENGTH, 2" MODEL NO. VBH77-12B-X LENGTH. BOTH MODELS 12" IN HEIGHT.

1.5" AND 2" IRRIGATION METER VAULT

Castle Pines North METROPOLITAN DISTRICT

Kennedy/Jenks Consultants Engineers & Scientists

NOTE:

PRIOR TO CONSTRUCTION, LOCATION OF REMOTE TRANSPONDER MUST BE APPROVED BY THE DISTRICT.

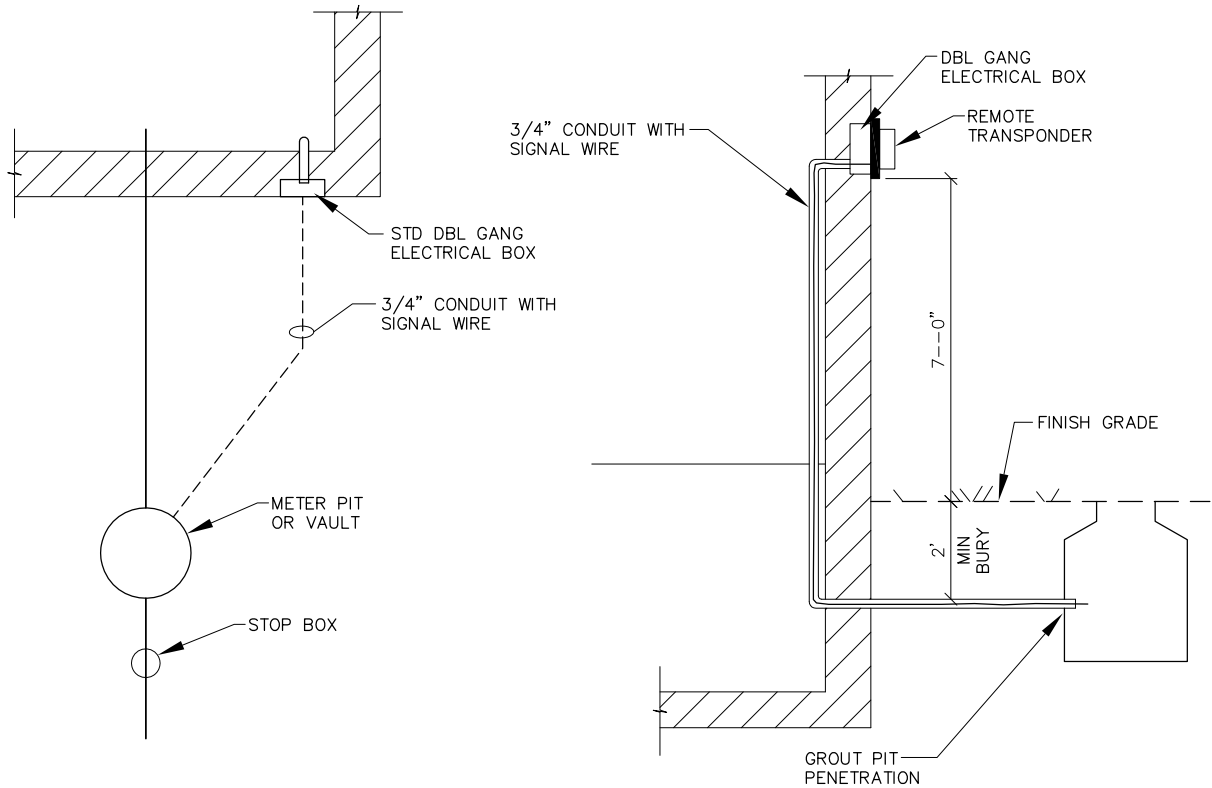

REMOTE TRANSPONDER
INSTALLATION

M *Castle Pines North*
METROPOLITAN DISTRICT

Kennedy/Jenks Consultants
Engineers & Scientists

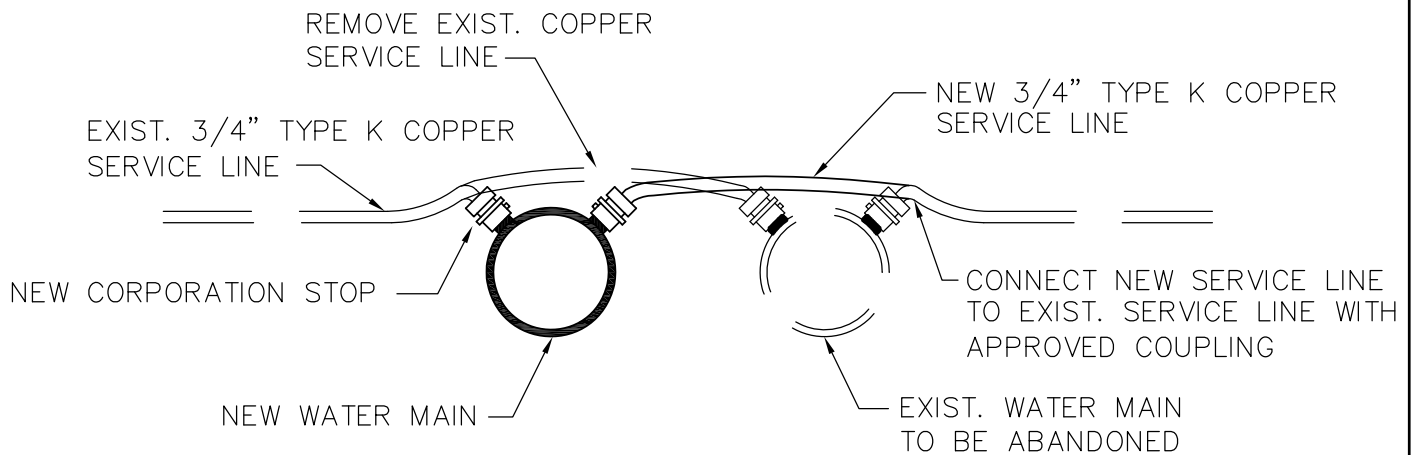

NOTES:

1. INSULATING COUPLING REQUIRED BETWEEN METALLIC WATER MAIN AND CORPORATION STOP.

DOMESTIC WATER SERVICE
RECONNECTION

M *Castle Pines North*
METROPOLITAN DISTRICT

Kennedy/Jenks Consultants
Engineers & Scientists

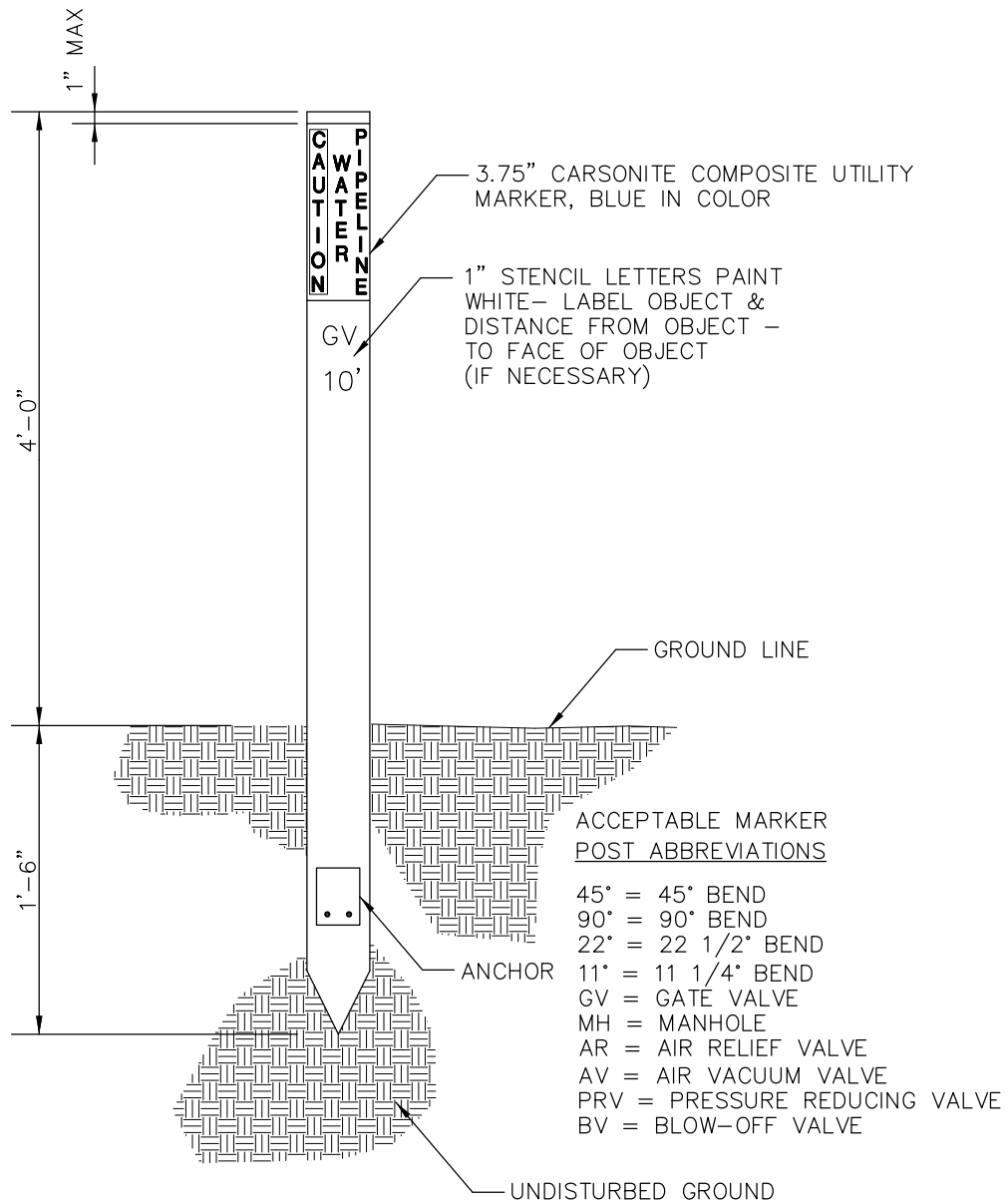

*CARSONITE MARKER POST ONLY TO BE USED WITH PRIOR APPROVAL BY THE DISTRICT.

CARSONITE MARKER POST

M *Castle Pines North*
METROPOLITAN DISTRICT

Kennedy/Jenks Consultants
Engineers & Scientists

6"x6" OR 4"x4" REDWOOD POST
WITH NECESSARY INFORMATION
TO BE ROUTED INTO MARKER POST

12" SIZE (12 INCHES)

G.V. OBJECT (GATE VALVE)

10' DISTANCE TO OBJECT

2" HIGH ROUTED CAPITAL
LETTERS TO FACE OBJECT.

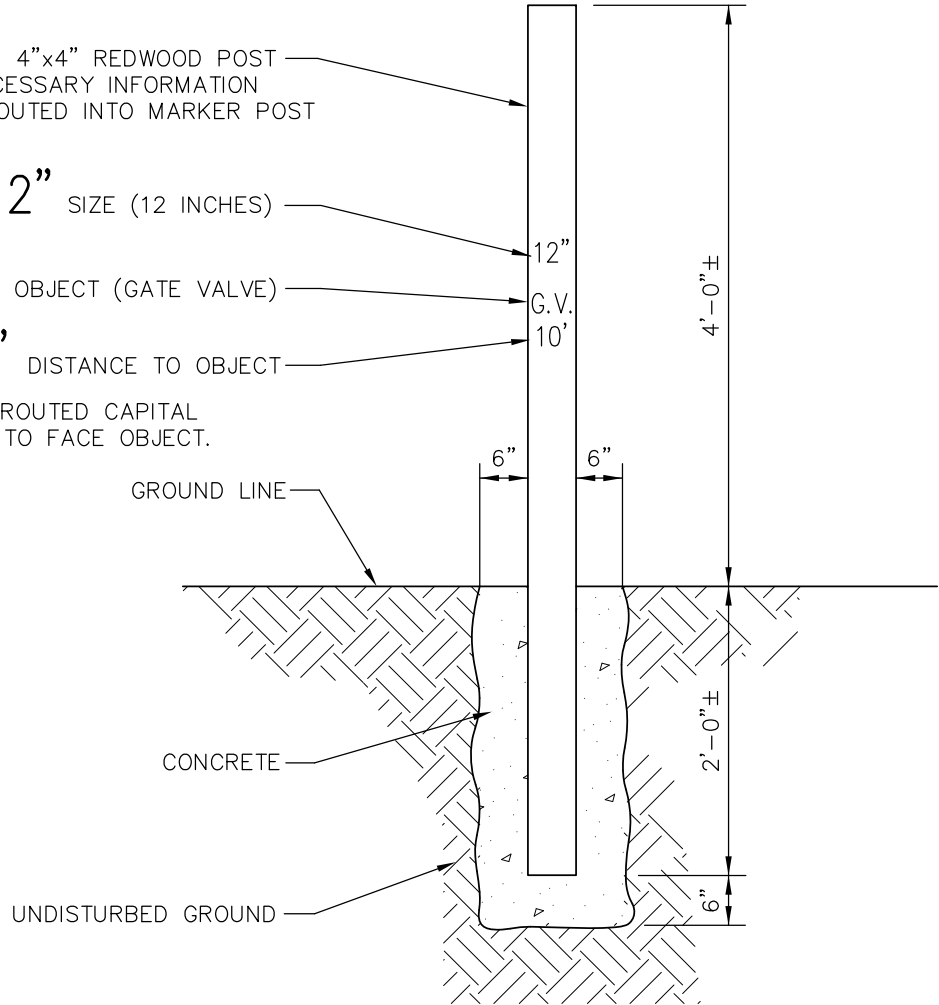

*REDWOOD MARKER POST ONLY TO BE USED WITH PRIOR APPROVAL BY THE DISTRICT.

REDWOOD MARKER POST

Castle Pines North
METROPOLITAN DISTRICT

Kennedy/Jenks Consultants
Engineers & Scientists

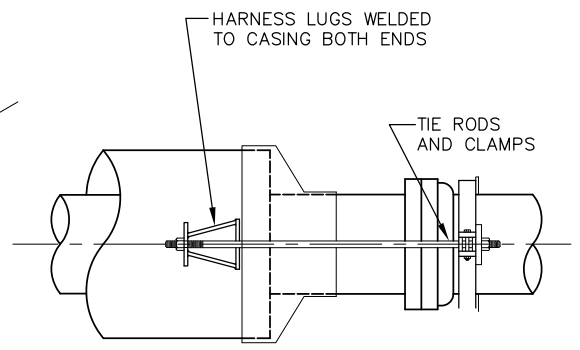
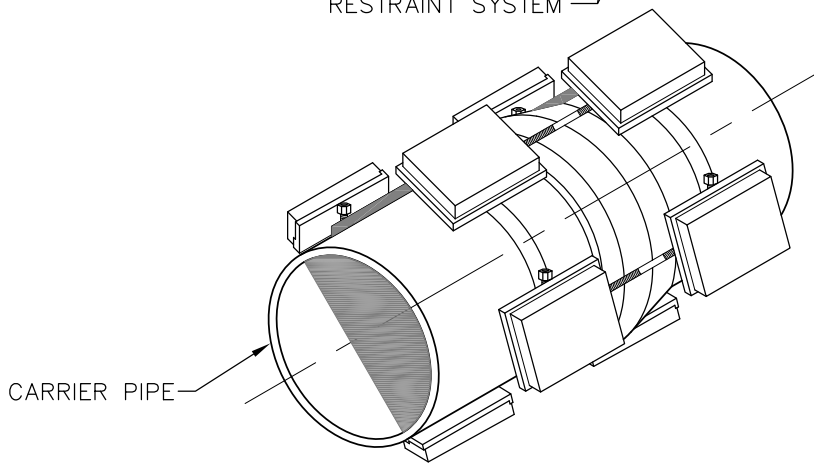
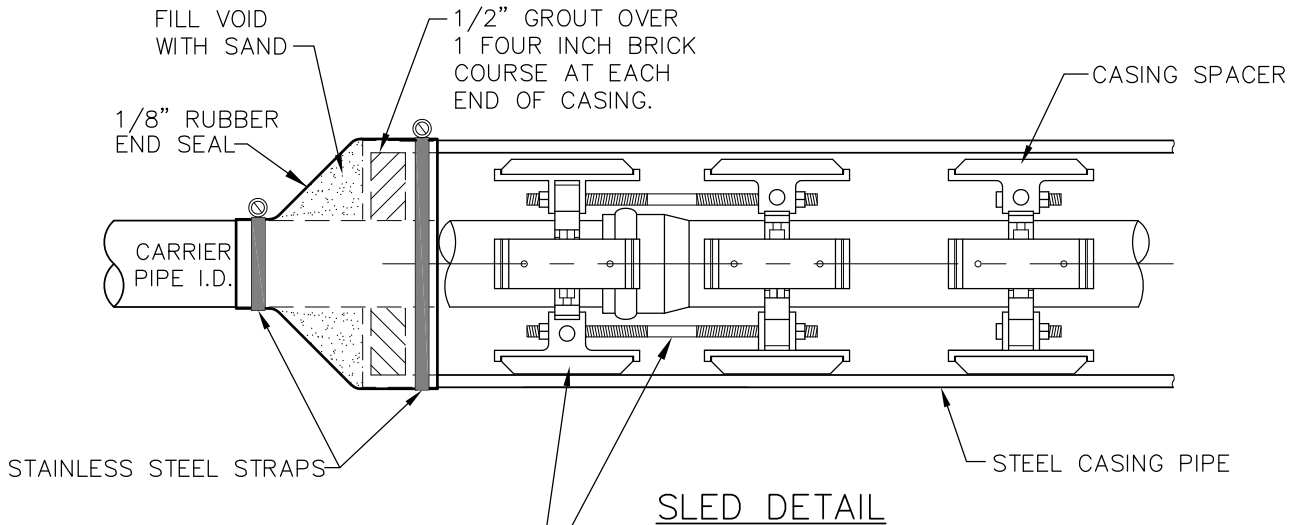

NOTES:
 1. HARNES LUGS TO BE INSULATED FROM DI PIPE

RESTRAINT TO CASING

NOTES:
 1. CASING SPACERS SHOULD BE INSTALLED EVERY 10' PER MANUFACTURER'S REQUIREMENTS.
 2. PROVIDE UNIFLANGE RESTRAINED CASING SPACERS 1300 & 1390 OR EQUAL.
 3. CASING MINIMUM WALL THICKNESS FROM DENVER WATER SPECS.

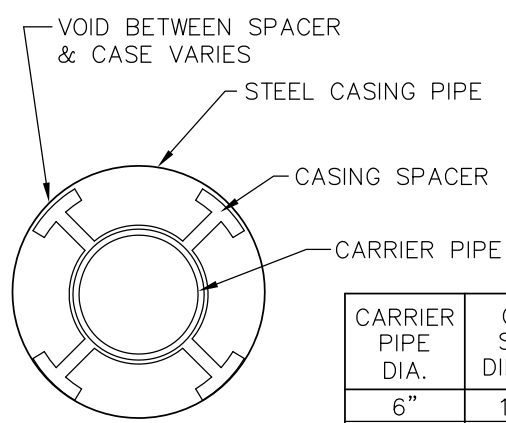

CARRIER PIPE DIA.	CASING SPACER DIMENSION	CASING O.D.	CASING MIN. WALL THICKNESS
6"	13.375"	16"	0.250"
8"	17.125"	18"	0.282"
12"	21.875"	24"	0.344
16"	28.375"	30"	0.406

**PIPE CASING & SLED
 POLYMER RUNNERS
 RESTRAINED CASING SPACERS**

**Castle Pines North
 METROPOLITAN DISTRICT**

Kennedy/Jenks Consultants
 Engineers & Scientists

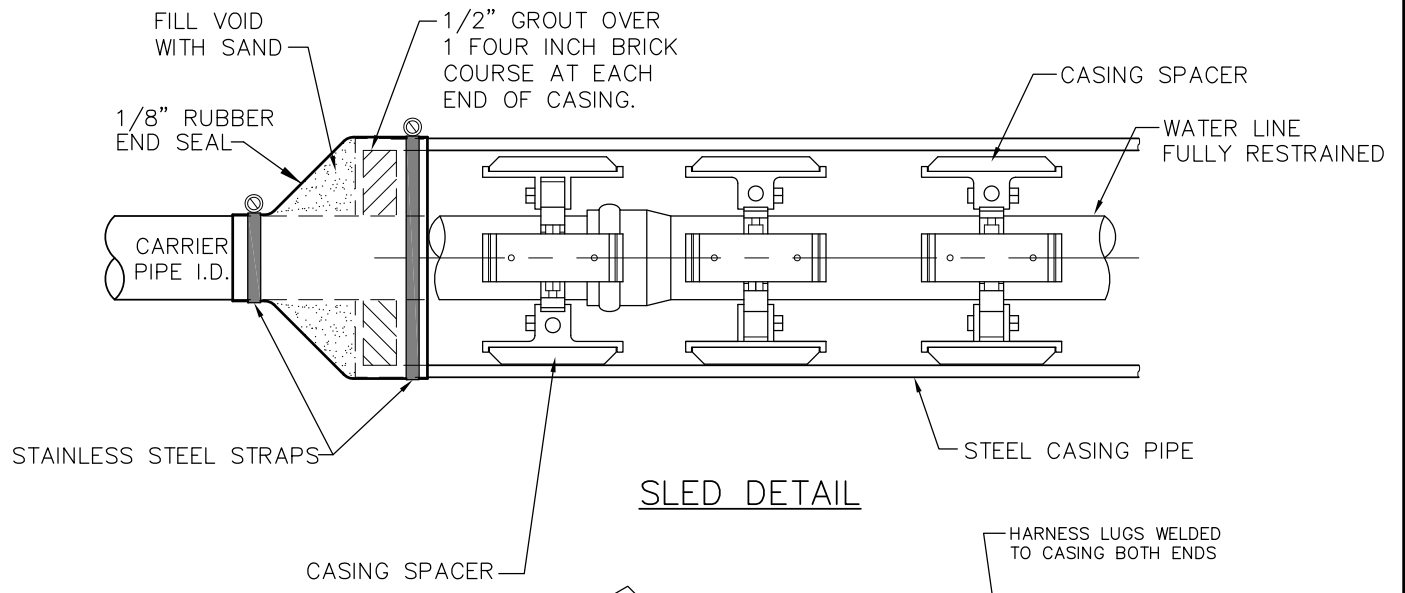

SLED DETAIL

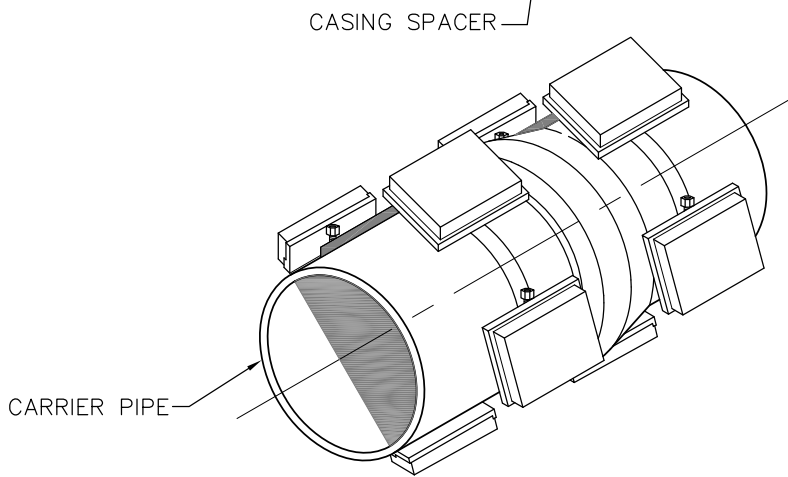

PIPE CASING DETAIL

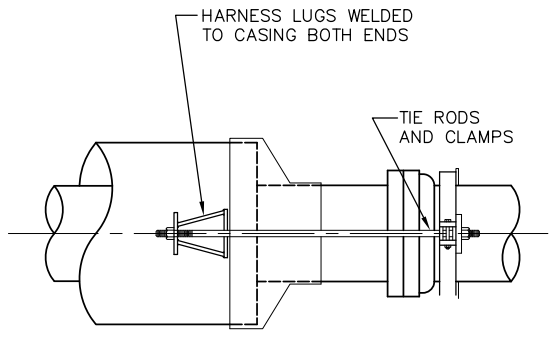

NOTES:

1. HARNESS LUGS TO BE INSULATED FROM DI PIPE

RESTRAINT TO CASING

NOTES:

1. CASING SPACERS SHOULD BE INSTALLED EVERY 10' PER MANUFACTURER'S REQUIREMENTS.
2. PROVIDE MEGALUG 1700 SERIES (FOR D.I.) OR 1500 PV SERIES (FOR PVC) WATER MAIN JOINT RESTRAINTS OR EQUAL.
3. CASING MINIMUM WALL THICKNESS FROM DENVER WATER SPECS.

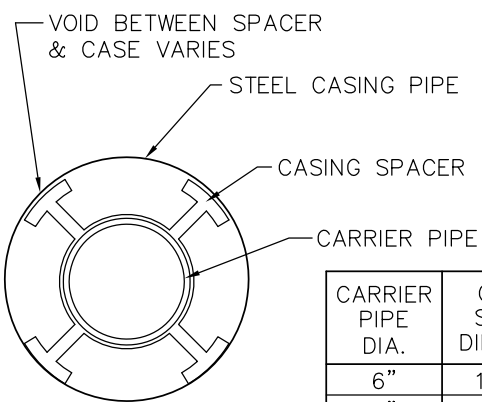

CARRIER PIPE DIA.	CASING SPACER DIMENSION	CASING O.D.	CASING MIN. WALL THICKNESS
6"	13.375"	16"	0.250"
8"	17.125"	18"	0.282"
12"	21.875"	24"	0.344
16"	28.375"	30"	0.406

**PIPE CASING & SLED
POLYMER RUNNERS
RESTRAINED WATER MAIN**

**Castle Pines North
METROPOLITAN DISTRICT**

Kennedy/Jenks Consultants
Engineers & Scientists

NOT USED



M *Castle Pines North*
METROPOLITAN DISTRICT

Kennedy/Jenks Consultants
Engineers & Scientists

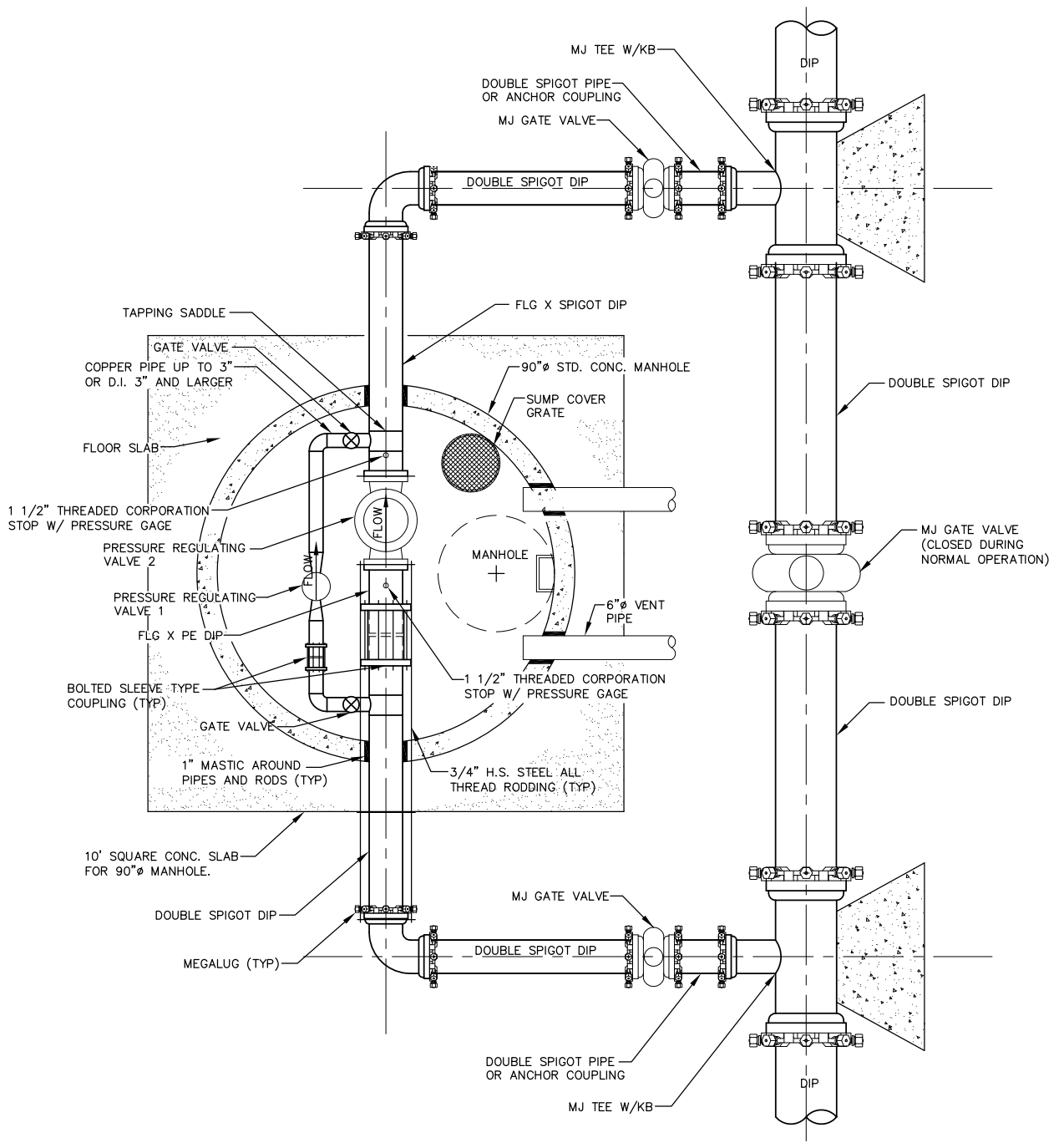

**PRESSURE REGULATING VALVE
PLAN VIEW**

Castle Pines North
METROPOLITAN DISTRICT

Kennedy/Jenks Consultants
Engineers & Scientists

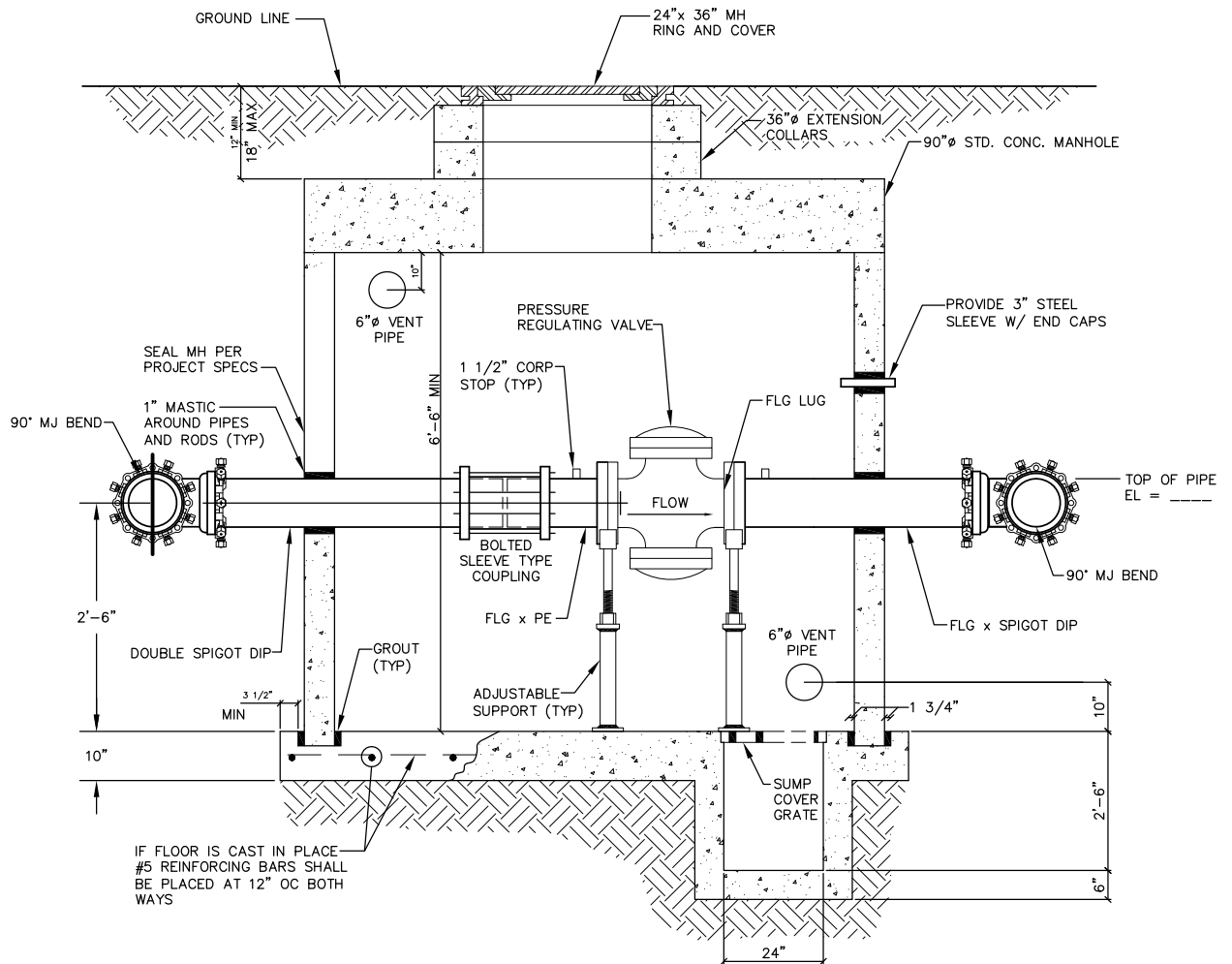

NOTES:

1. LADDER RUNGS ARE REQUIRED IN PRE-CAST MANHOLE. THE DISTANCE BETWEEN RUNGS, CLEATS, AND STEPS SHALL NOT EXCEED 12" AND SHALL BE UNIFORM THROUGHOUT THE LENGTH OF THE LADDER.
2. PRV VALVES SHALL BE CLA-VAL 90-01 OR APPROVED EQUAL.
3. ALL PIPING FOR PRV VALVE INSTALLATIONS SHALL BE DUCTILE IRON PIPE AND SHALL BE FULLY RESTRAINED.
4. DO NOT PLACE SUMP DIRECTLY UNDER MANHOLE OPENING.
5. DEPTH AT VAULT MAY NEED TO BE DEEPER THAN 5.0 FT. TO ACCOMMODATE VAULT.
6. **MECHANICAL PIPING PAINT**

THE CONTRACTOR SHALL BE RESPONSIBLE FOR PAINTING ALL NEW FERROUS BASED PIPE FITTINGS, VALVES AND APPURTENANCES AND FOR TOUCHING UP ANY EXISTING PIPING WHICH HAS BEEN MARRED, OR SCRATCHED IN THE COURSE OF CONSTRUCTION.

BEFORE PAINTING, CLEAN AND PRIME THE SURFACE IN ACCORDANCE WITH SSPC-SP2 (HAND TOOL CLEANING.) RE-PRIME ALL CHIPPED OR DAMAGED PAINT. APPLY PAINT IN TWO COATS IN ACCORDANCE WITH MANUFACTURER'S INSTRUCTION. THE PAINT SHALL BE ALKYD (OIL BASED ENAMEL). COLOR SHALL BE SAFETY BLUE AS MANUFACTURED BY TNEMEC.

PRESSURE REDUCING VALVE INFORMATION

PRV	SIZE	INLET HGL FT. USGS	OUTLET HGL FT. USGS	PRV ELEVATION	INLET STATIC PRESSURE	OUTLET STATIC PRESSURE	MAX DESIGN FLOW
1	3"	-----	-----	-----	--- psi	--- psi	---- gpm
2	6"	-----	-----	-----	--- psi	--- psi	---- gpm

PRESSURE REGULATING VALVE SECTION VIEW

Metropolitan DISTRICT
Castle Pines North

Kennedy/Jenks Consultants
 Engineers & Scientists

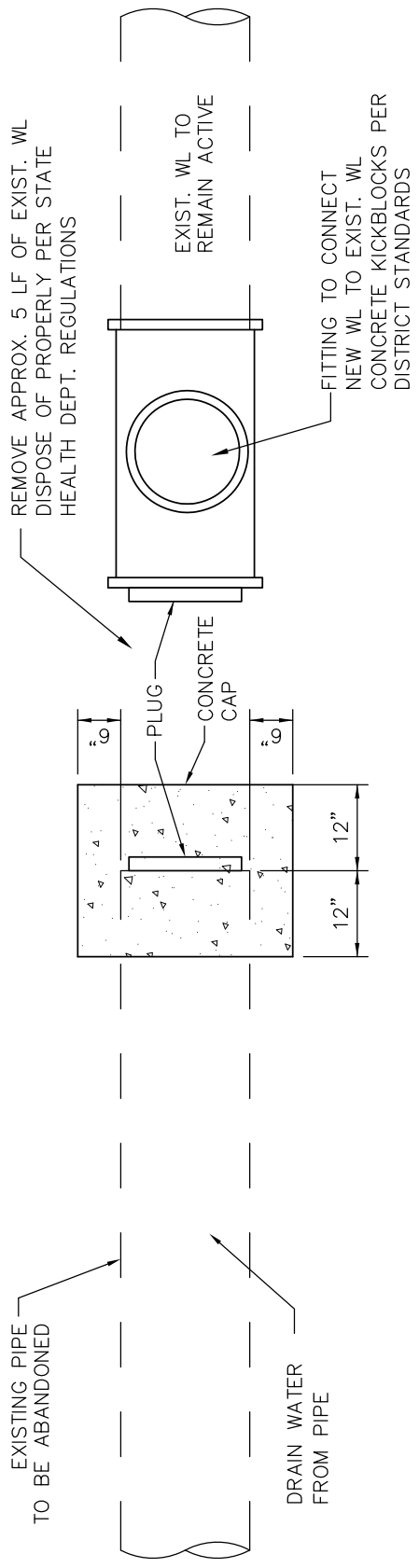

PIPE ABANDONMENT

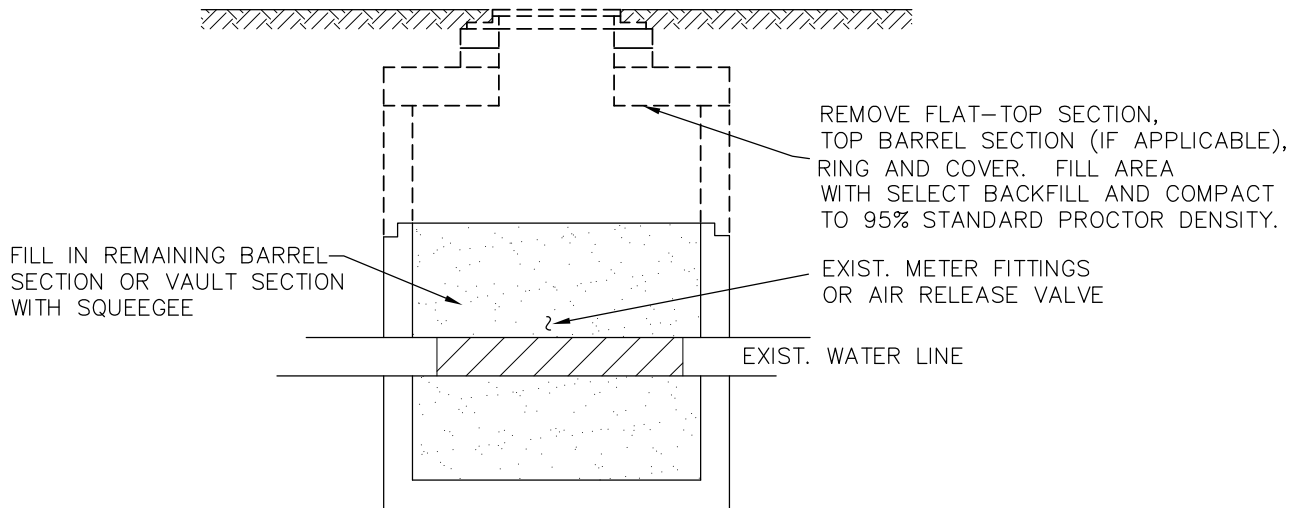

PROFILE

NOTES:

1. REMOVE METER, AIR RELEASE VALVES, AND ALL RELATED PIPING IN VAULT.
2. CLOSE REMAINING GATE VALVES.
3. INSTALL BLIND FLANGE PLUGS ON PIPE ENDS.
4. CONTACT DISTRICT PRIOR TO REMOVAL OF METER FOR A FINAL READING.

WATER VAULT ABANDONMENT

M *Castle Pines North*
METROPOLITAN DISTRICT

Kennedy/Jenks Consultants
Engineers & Scientists

FIRE DEPARTMENT APPROVAL

ALL FIRE HYDRANTS SHALL BE INSTALLED ACCORDING TO
CASTLE PINES NORTH METROPOLITAN DISTRICT STANDARDS.
THE NUMBER OF FIRE HYDRANT LOCATIONS AS SHOWN
ON THESE PLANS ARE CORRECT AND ADEQUATE TO
SATISFY THE FIRE PREVENTION REQUIREMENTS AS SPECIFIED
BY THE SOUTH METRO FIRE PROTECTION DISTRICT.

SIGNATURE OF FIRE CHIEF OR
REPRESENTATIVE

ESTIMATED FIRE FLOW: _____ G.P.M.

DATE